



YASHOMANTHAN

(A Peer Review Management Research Journal)

IMPACT
FACTOR :
6.692

RESEARCH JOURNAL

Indexed by

Scientific Journal Impact Factor

INDEX

Sr. No.	Paper Title	Page No.
1	Speech Recognition Using Recurrent Neural Network (RNN) Mr. Danish Nazir Raja, Mr. Kaiser Javeed Giri, Ms. Iqra	1
2	Deep Learning based Small Object Detection and its Applications Ms. Iqra, Mr. Kaiser Javeed Giri, Mr. Danish Nazir	7
3	Financing of Business - Mr.Sanjay Aghav	13
4	Data visualization Concept of Data Science - Mrs. Smita Shashikant Patil	19
5	Blockchain Based E-voting System Prashant Govardhan, Payal Chandel, Anand Kankirad, Nirmiti Meshram, Shlok Mishra, Natasha Wanjari	23
6	Object Detection On Construction Site - Rupali Saha, Snehal Motghare, Aachal Mate, Tanushri Sapate, Kirti Gokhale, Sakshi Channe	27
7	Design and Analysis of Roll Cage of Electric Cargo Vehicle Manasi Gawali, Akshay Madane, Raghavendra Kerkar, Rohit Kale	33
8	Analysing Work Life Balance Of Organised & Unorganised Sector Female Workers In India - Ms. Vanshika Sharma, Mr. Priya Pawar, Mr. Arihant Sutar	42
9	Adoption & Usage of Online Payment Apps by Marginalized Communities in Pune District. - Manya Basrani, Muskan Kumari, Priyanka Singh	47
10	Big data predictive analytics for e-governance: Analysing and managing data through data analytics Ms. Priyanka Sakat	53
11	Leading Organizational Digital Transformation Using Low Code Ms. Veena Badgujar, Ms. Pranali Vhora	57
12	Empirical Exposition Model to Analyze Suicide Causes in India Dr. Poonam Sawant, Prof. Yogesh Sharma, Prof. Navnath Choudhari, Mr. Mihir Limje	63
13	Impact of Communication on International Business: The Case of Buenos Aires Case - Dr. Pradeep Kumar	68

ADVISORY BOARD

Hon'ble Vishwesh Kulkarni
President,
Yashaswi Education Society

Dr. Abhishek Kulkarni
Managing Director,
Yashaswi Education Society

EDITORIAL BOARD

DR. SHIVAJI MUNDHE

EDITOR-IN-CHIEF

Yashomanthan, Research Journal
DIRECTOR
IIMS, Chinchwad, Pune
Mob. : 9822242322
Email : iims.director@yashaswigroup.in

DR. VANDANA MOHANTY

EDITOR

Yashomanthan Research Journal
Associate Professor, HOD MBA & IQAC
IIMS, Chinchwad, Pune
Email : lims.faculty@yashaswigroup.in

DR. SACHIN MISAL

CO-EDITOR

Yashomanthan Research Journal
Assistant Professor, IIMS,
faculty@yashaswigroup.in
IIMS, Chinchwad, Pune.
Email :iims.research@yashaswigroup.in

DR. SHAD AHMAD KHAN

ASSISTANT PROFESSOR

College of Business,
University of Buraimi, Al Buraimi,
Sultanate of Oman

Email :
shad.a@uob.edu.om

DR. KORHAN CENGIZ

ASSOCIATE PROFESSOR

Department of Computer Engineering ,
Istinye University, 34010,
Istanbul, Turkey.

Email :
korhan.cengiz@istinye.edu.tr

DR. PRADEEP KUMAR

FOUNDER & PRESIDENT,

Indo-European Education,
Warsaw, Poland.

Email :
p.kumar@ieef.pl

DR. SYRIAC N. DEVASIA

DEAN

Faculty of Business and Accountancy,
PERDANA University, Kuala Lumpur

Email :
syriac@perdanauniversity.edu.my

DR. PALANIVEL R. VELMURUGAN

LECTURER

Berlin School of Business & Innovation GmbH
Alte Post Karl-Marx-Straße 97-99,
12043, Berlin Germany

Email ;
palanivel.velmurugan@berlinsbi.com

DR. SMITA SINGH (DABHOLKAR)

ASSOCIATE PROFESSOR,

Institute of Management Technology,
Nagpur. India

Email
sdabholkar@imtnag.ac.in

DR. B. SURESH KUMAR

ASSOCIATE PROFESSOR

Amity School of Engineering and
Technology (ASET) Kant Kalwar, NH-11C,
Jaipur (Raj.), India -303002.

Email :
bskumar@jpr.amity.edu

DR.CHANDRAHANS CHAVAN

Jamnalal Bajaj Institute of Management,
Mumbai, India.

Email :
crchavan@jbims.edu

DR.MARULKAR KEDAR VIJAY

ASSISTANT PROFESSOR

Department of Commerce and Management,
Shivaji University,
Kolhapur, India - 416004

Email :
kvm_commerce@unishivaji.ac.in

DR. GANGA DHAR DAHAL

PRINCIPAL

Global College of Management and
Board Director of Global College International
and Uniglobe Secondary School. Nepal

Email :
gddahal@uniglobe.edu.np

About Yashomanthan Research Journal

The Yashomanthan is an annual double-blind, peer reviewed journal that has been published since the year 2014. The journal's mission is to bring out the latest in management thought, academic research and corporate practice across all domains of business and management in a reader- friendly format. We welcome submissions that are innovative in ideation, conceptually sound, methodologically rigorous and contribute substantially to business and management literature. The journal targets both national and international audience that encompasses the entire business and management fraternity, in both industry and academia.

Aim & Scope of Yashomanthan Research Journal:

Our aim is to provide an avenue for the publication of the latest advancements in quality research output across all management functional areas while supporting our authors with constructive reviews and feedback from our expert reviewers throughout the publication process. We target the highest quality standards both in terms of timely delivery of research output as well as strict compliance to the principles laid out by the Committee on Publication Ethics (COPE). At no point do we charge any publication/ article processing fee. We are committed to publishing high-quality, open- access research to contribute to the expansion of scientific knowledge for the public good. Yashomanthan welcomes empirical and theoretical articles dealing with micro and macro workplace phenomena. Manuscripts that are suitable for publication in the Yashomanthan cover domains such as business strategy and policy, entrepreneurship, human resource management, Computer management, IT, organizational behaviour, organizational theory, and research methods.

Yashomanthan Research Journal publish research paper & review papers Related to Following Management Subjects:

Finance, Marketing, Human Resource Management, Marketing, Commerce, Business & Health Care Management, Hotel Management, Mass Communication, Economics, Corporate Governance, Tourism, Accounting, Logistics and Supply Chain Management, Computer Management, Architecture.

Publication Frequency	:	Annually (Once in Year)
Journal Type	:	Management
Starting Year	:	2014
Journal Email	:	editor@yashomanthan.co.in

**© 2023 International Institute of Management Science,
Pune. All rights reserved.**

This journal and the individual contributions contained in it are protected by the copyright International Institute of Management Science, Pune and the following terms and conditions apply to their use:

Photocopying: Single photocopy of single article may be made for personal use as allowed by national copyright laws. Permission of the publisher and payment of a fee is required for all other photocopying, including multiple or systematic copying, copying for advertising or promotional purposes, resale, and all forms of document delivery.

Permissions may be sought directly from The Editor, YASOMANTHAN, International Institute of Management Science, Pune. Yashaswi Bhavan, Opp. Elpro International, Near Ramkrishna More Auditorium, Chinchwad, Pune-411033.

Derivative Works: Subscribers may reproduce tables of contents or prepare lists of articles including abstracts for internal circulation within their institutions.

Electronic Storage or Usage: Permission of the Publisher is required to store or use electronically any material contained in this journal, including any article or part of an article.

Except as outlined above, no part of this publication may be reproduced, stored in a retrieval system or transmitted in any form or by any means, electronic, mechanical, photocopying, recording or otherwise, without prior written permission from The Editor, YASOMANTHAN, International Institute of Management Science, Pune. Yashaswi Bhavan, Opp. Elpro International, Near Ramkrishna More Auditorium, Chinchwad, Pune-411033.

Disclaimer: The publisher, International Institute of Management Science, Pune and editors cannot be held responsible for errors or any consequences arising from the use of information contained in this journal. Views and opinions expressed in the articles/papers do not necessarily reflect those of the publisher and editors. All efforts are made to ensure that published information is correct. The publishers and editors are not responsible for any errors caused due to oversight or otherwise.

INDEX

Sr. No.	Paper Title	Page No.
1	Speech Recognition Using Recurrent Neural Network (RNN) Mr. Danish Nazir Raja, Mr. Kaiser Javeed Giri, Ms. Iqra	1
2	Deep Learning based Small Object Detection and its Applications Ms. Iqra, Mr. Kaiser Javeed Giri, Mr. Danish Nazir	7
3	Financing of Business - Mr.Sanjay Aghav	13
4	Data visualization Concept of Data Science - Mrs. Smita Shashikant Patil	19
5	Blockchain Based E-voting System Prashant Govardhan, Payal Chandel, Anand Kankirad, Nirmiti Meshram, Shlok Mishra, Natasha Wanjari	23
6	Object Detection On Construction Site - Rupali Saha, Snehal Motghare, Aachal Mate, Tanushri Sapate, Kirti Gokhale, Sakshi Channe	27
7	Design and Analysis of Roll Cage of Electric Cargo Vehicle Manasi Gawali, Akshay Madane, Raghavendra Kerkar, Rohit Kale	33
8	Analysing Work Life Balance Of Organised & Unorganised Sector Female Workers In India - Ms. Vanshika Sharma, Mr. Priya Pawar, Mr. Arihant Sutar	42
9	Adoption & Usage of Online Payment Apps by Marginalized Communities in Pune District. - Manya Basrani, Muskan Kumari, Priyanka Singh	47
10	Big data predictive analytics for e-governance: Analysing and managing data through data analytics Ms. Priyanka Sakat	53
11	Leading Organizational Digital Transformation Using Low Code Ms. Veena Badgujar, Ms. Pranali Vhora	57
12	Empirical Exposition Model to Analyze Suicide Causes in India Dr. Poonam Sawant, Prof. Yogesh Sharma, Prof. Navnath Choudhari, Mr. Mihir Limje	63
13	Impact of Communication on International Business: The Case of Buenos Aires Case - Dr. Pradeep Kumar	68

SPEECH RECOGNITION USING RECURRENT NEURAL NETWORK (RNN)

Danish Nazir Raja
danish.raja@iust.ac.in

Kaiser Javeed Giri
kaiserjaveed@gmail.com

Iqra
iqra@iust.ac.in

Department of Computer Science Islamic University of Science and Technology
1-University Avenue. Awantipora, Pulwama, Pin -192122 Jammu and Kashmir, India.

Abstract

Information Technology has expanded into new realms, largely to make daily life easier for people. The Artificial Intelligence (AI) transformed almost everything. Every now and then, innovations are occurring in numerous fields including education, business, healthcare, etc. AI has achieved great in the discipline of Natural Language Processing (NLP) & Speech Processing and has also made considerable strides in the field by creating a system that manipulates speech signals to convert one language to another, identify a language, etc. Speech recognition is an important and rapidly evolving field of research that has numerous practical applications. Speech Recognition is a fascinating area in the realm of human-computer interaction that provides the chance to engage and command the machine. In recent years, recurrent neural networks (RNNs) have been shown to be effective for speech recognition tasks, outperforming traditional methods such as hidden Markov models (HMMs). This paper investigates the use of RNNs for speech recognition, exploring their strengths and weaknesses relative to other methods. The paper provides an overview of the history and current state of speech recognition, including an introduction to RNNs and a comparison with HMMs then it describes the RNN architecture including the choice of activation functions, loss functions, and optimization algorithms. Additionally, the RNNs were found to be more robust to noise and variations in speaking style, which can often pose challenges for traditional speech recognition methods. In conclusion, this paper demonstrates the effectiveness of RNNs for speech recognition and highlights the potential for further improvements using more advanced architectures and techniques.

Keywords—Artificial Intelligence, Speech Recognition, Speech to text, Convolutional Neural Networks, Recurrent Neural Networks, Hidden Markov Models.

I. INTRODUCTION

Natural Language Processing is referred to as NLP [1]. It is an area of computer science and artificial intelligence that is concerned with the use of human language to interact between machines and people. The goal of NLP is to facilitate the ability for machines to read, interpret, and produce human language in a

usable and meaningful manner. NLP involves use of computational algorithms, statistical models, and linguistic expertise to analyse, comprehend, process, and produce human language. Written text, spoken language, and sign language are all types of data that NLP accepts. The discipline of NLP is rapidly advancing, with many fascinating innovations and thriving areas like Conversational AI [2], Sentiment Analysis [3], Machine Translation [4], Named Entity Recognition [5], Text Summarization [6] and many more. There are several prospects for study and innovation in the fast-developing field of NLP, which has many fascinating advancements and thriving regions. Exploring speech recognition using RNNs can be an enriching experience, particularly for those intrigued by the intersection of computer science, mathematics, and linguistics. It entails studying different disciplines and their integration, presenting an opportunity for holistic learning. Moreover, delving into this area can offer thrilling prospects for creating valuable contributions to the field of signal processing and artificial intelligence. Although the NLP field has undeniably evolved significantly, it still finds it difficult to pinpoint nuances like Ambiguity, Syntax, Context, dialectical variances. Since communication is crucial for building and maintaining relationships, sharing information, problem-solving, decision-making, and achieving common goals. Because it facilitates social contact, emotional expression, and the development of relationships with others, human communication is crucial. Individuals are capable of expressing understanding, communicate their thoughts, feelings, and ideas, and exchange information. Since speech is the building block of communication and is most widely utilised form of human communication because it is quick, effective, and highly expressive. Speech, in contrast to all other forms of communication, enables people to express themselves verbally with a great degree of nuance and emotional expressiveness. Humans are more accustomed to speaking than they are to using simple tools like keyboards or pointing devices, thus they would probably prefer to engage with computers via voice-based interfaces [7]. The goal can be accomplished by constructing a system for Automatic

Speech Recognition (ASR). ASR is a method that renders it possible for a computer or other device to understand and identify spoken language. As a result, ASR has the ability to be a crucial method for human-computer interaction. The significance of ASR rests in its capacity to convert speech into output that is readable by machines. The basic recognition of speech system is shown in fig. 1.

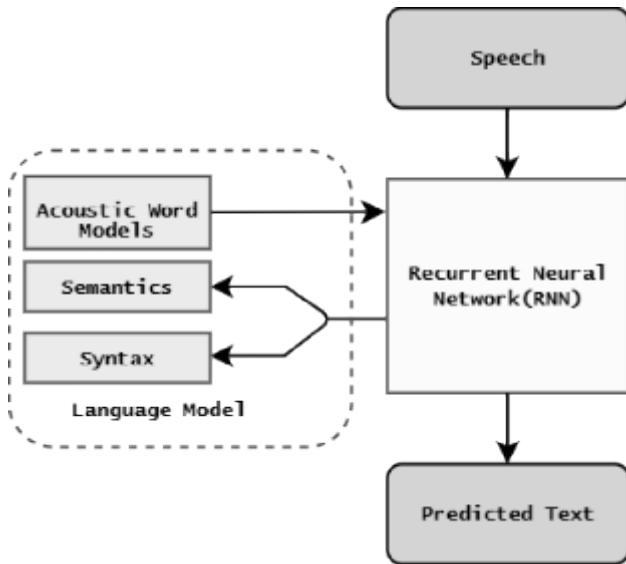

Recurrent neural networks (RNN) are a popular technique for processing and understanding spoken language and are used for speech recognition. RNNs are a particular type of neural network that perform well with sequential input, like speech [8]. The fundamental concept underlying speech recognition using RNNs is to input the network a sequence of audio features, often in the form of spectrograms or Mel frequency cepstral coefficients (MFCCs) [9]. In order to gather details about the context and temporal relationships of the speech, the network analyses the sequence of features using the RNN's hidden state.

The Long Short-Term Memory (LSTM) network is one RNN type that is frequently employed in voice recognition [10]. The vanishing gradient issue that may arise in conventional RNNs and make it challenging for the network to learn long-term relationships is something that LSTMs are intended to solve.

A collection of speech recordings and related transcripts is often utilised to train the network. Given a series of audio characteristics, the network is trained to predict the most probable transcript. This is accomplished by comparing the predicted transcript to the ground truth transcript using a loss function, like the cross-entropy loss.

Once the network is trained, it can be used to recognize speech in real time by feeding it a stream of audio features and decoding the most likely transcript using a language model or other decoding algorithm.

The objective of the paper includes understanding of the

Speech recognition using RNN techniques & difficulties that arise when detecting speech in applications areas of speech recognition and the importance of developing recognition methods that are both precise and efficient. The paper intends to examine the most advanced deep learning methods for detecting speech signals, with particular emphasis on Recurrent Neural Networks. Also, the paper seeks to emphasize the potential research avenues and future directions in the realm of detecting speech recognition using deep learning techniques.

II. LITERATURE REVIEW

The initial Speech Recognition System, known as the "Audrey" system, was developed in the 1950s by David et al [11, 12], at Bell's Laboratories. This system could recognise a single voice speaking numbers aloud. Here is where the foundations of ASR and signal processing methods can be traced. And thereafter, in the 1960s, a number of Japanese research institutions showed off their ability to create specialised hardware for voice recognition. The late 1960s saw the invention of Hidden Markov Models [13,14]. The advent of faster microprocessors made speech recognition technology viable. The first consumer speech recognition technology was introduced by Dragon in 1990 with release of Dragon Dictate [15]. It was improved in 1997, and Dragon Naturally Speaking [16] was developed. Up to 99% accuracy in English recognition was achieved by Dragon Mobile SDK. Heckmann et al. [17] presented a hybrid Artificial Neural Network/ Hidden Markov Model (ANN/HMM)-based system for audio-visual speech recognition in 2001, when the advancement of the field of voice recognition was reached a plateau. A relatively novel concept in continuous word recognition, these hybrid systems produce performance on par with pure HMM systems. Since then, the field has seen significant advancements thanks to the introduction of Google Voice Search [18], which uses data centres to handle the enormous amount of data processing necessary to match user searches with actual instances of human speech. Google Voice Search uses information from billions of searches to enable it to be able to anticipate what someone is actually saying.

In 2011, Apple [19] designed a personal assistant

Speech Interpretation and Recognition Interface (SIRI) that is comparable to Google's Voice Search. Since then, improved speech recognition technologies have become commonplace in everything from computers and smartphones to autos, refrigerators, watches, and video games, including Amazon's Alexa [20], Google Assistant [21], and Siri [22].

Later, tech firms introduced voice instructions to do away with the distraction of looking down at a mobile device while driving. It is critical to understand that there are still some bugs. Studies have shown that voice-activated auto technology can cause additional cognitive distractions, however self-driving cars have recently gained popularity and reduce all the concerns. Major developments are being occurring in the realm of speech recognition, which is an active field of research.

III. RNN BASED SPEECH RECOGNITION TECHNIQUES

Recurrent Neural Network (RNN) is a form of Neural Network designed to handle data that is presented in a sequence. It may loop back and use data from earlier steps in the sequence to aid process the following step, which is why it is named "recurrent" in the name of the algorithm [23]. As a result, RNNs are better able to recognise patterns and connections in the data, which helps them in applications like speech and language processing. Some of the commonly used RNN architectures for Speech Recognition include LSTM, GRU, Deep RNN, Attention-based RNN.

- **Long Short-Term Memory (LSTM)** is a form of artificial neural network that excels at processing input that is presented in sequences, such as sentences or speech. In contrast to conventional neural networks, LSTMs have the ability to selectively recall or forget information as necessary. LSTMs are employed in applications like speech recognition and language modelling, and image captioning due to their proven excellent performance for a variety of tasks in these fields. The input gate, forget gate, and output gate are the three basic components of the LSTM neural network's architecture. A memory cell that saves data over time also forms part of the design.

The input gate makes the decision of how much input should be fed to the memory cell. A sigmoid activation function is used to produce values between 0 and 1 using the input value and the prior hidden state. This gate essentially determines which portion of the input has to be kept. The information to be removed from the memory cell is determined by the forget gate. Values

between 0 and 1 are produced by applying a sigmoid activation function to the input value and the prior hidden state as inputs. This sigmoid value is multiplied by the prior memory cell state to determine which portion of the information should be forgotten. How much of the memory cell should be used to produce the output is decided by the output gate. An activation function called tanh is then applied to the memory cell state, which compresses values between -1 and 1. Using the output of the tanh activation function and the sigmoid value, the output gate multiplies them to determine which region of the memory should be used to generate the output.

The memory cell transfers the information to the subsequent time step after storing it throughout time. As a result, the network can retain information for a long time, making it suitable for processing sequential data.

- **Gated Recurrent Unit (GRU)** it belongs to a category of recurrent neural networks (RNNs) made to recognise long-term relationships in sequential data. Compared to the LSTM, the GRU has fewer parameters and requires less computing power. Two gates—the update gate and the reset gate—make up the architecture of a GRU network. The reset gate accepts the previous hidden state and the current input as inputs and uses a sigmoid activation function to decide whether portions of the prior hidden state should be reset or forgotten. In order to create an intermediate state that acts as the foundation for the potential hidden state, the output of the reset gate is multiplied by the previous hidden state. The update gate still accepts the prior concealed state and the current input as inputs, but it additionally applies two activation functions: a sigmoid function and a hyperbolic tangent (tanh) function. The sigmoid function determines how much of the previous hidden state should be kept, whereas the tanh function creates a potential hidden state. Finally, the updated hidden state is sent through a linear activation function to produce the GRU network's output.
- **Deep RNN Deep RNNs (Recurrent Neural Networks)** are a particular sort of neural network design that have several recurrent layer layers. The architecture of a Deep RNN (Recurrent Neural Network) is an extension of the basic RNN architecture, which has multiple layers of recurrent layers stacked on top of each other. Using this design, the network can recognise intricate temporal connections in sequential data since output from one recurrent layer is transmitted as input to the subsequent recurrent layer. First, the input data is passed into the first recurrent

layer, which produces an output. The second layer then receives this output as input and produces a different output. This procedure keeps on till the final recurrent layer's output is generated. A unique set of parameters for each recurrent layer in the architecture is learnt during training. This makes it possible for the network to collect data at many levels of abstraction. More complex temporal relationships can be captured by a network as it becomes deeper. Deep RNN training can be difficult, however a number of methods have been put out to address the vanishing gradient issue and enable more effective training.

- **Attention-Based RNN** An attention-based RNN is a particular kind of neural network design that enables the network to choose to focus on particular segments of the input sequence rather than processing the full sequence in one go. There are three primary components that constitute an attention based RNN's architecture an encoder RNN, an attention mechanism, and a decoder RNN. The encoder RNN analyses the input sequence and produces a series of hidden states. A straightforward RNN, LSTM, or GRU can be used as the encoder. The attention mechanism receives the output from the encoder. Based on the decoder's current state, the attention mechanism determines a weight or relevance score for each concealed state in the encoder output sequence. The relevance of each concealed state in relation to the decoder's current state is indicated by the weight score. To make sure that they add up to one, these weight scores are adjusted. Next, a context vector representing the most essential portions of the input sequence for the current decoder output is generated by calculating the weighted sum of the encoder hidden states. Based on the context vector and the output of the preceding decoder, the decoder RNN creates the output sequence. In conclusion, the Attention-based RNN architecture processes the input sequence through an encoder RNN, develops a context vector based on an attention mechanism, and produces the output sequence through a decoder RNN.

IV. APPLICATIONS AND CHALLENGES

Applications

Speech Recognition finds its use in multiple fields, some of which include:

- **Virtual Assistants:** Virtual assistants are employed to comprehend the user's spoken orders, reply with the required actions, and carry out a range of functions and services for users, frequently using voice recognition [24]. Some of the virtual assistants are Siri, Google Assistant, and Alexa. These may be implemented into

many different devices, including smartphones, smart speakers, and other internet-connected gadgets, and are made to simulate human interactions.

- **Speech-enabled Gaming:** Games that uses speech recognition technology to provide voice controls for game characters or activities is referred to as speech-enabled gaming. Players may interact with the game using their voice in speech-enabled gaming, creating a more intuitive and engaging gaming experience [25]. Accessibility for gamers with disabilities can be increased with the use of speech-enabled gaming. Voice instructions, for instance, can be used to browse the game and carry out activities by players with poor vision or restricted movement.
- **Automated Transcription:** Automated transcription is the practise of automatically converting audio or video recordings into text documents using artificial intelligence (AI) technology [26]. Natural language processing (NLP) methods and machine learning algorithms are combined in this technology to accurately detect, and record spoken phrases. Many contexts, including business meetings, interviews, seminars, and webinars, might benefit from automated transcribing. Compared to manual transcription, which calls for someone to listen to the audio and write it down word-for-word, it can save time and money.
- **Language Translation:** The process of translating text or voice from one language into another is known as language translation. This can be carried out automatically by machine learning and artificial intelligence (AI)-based translation systems.[4] These translators convert sentences into other languages by analysing and comprehending the grammar and meaning of the original phrases using algorithms. They utilise statistical models and neural networks to discover correlations and patterns among words and phrases in several languages, and they then use this understanding to translate text or voice.
- **Call Center Automation:** Artificial intelligence (AI) and machine learning technologies are used in call centre automation employing voice recognition to identify and record spoken words during customer interactions. The efficiency and accuracy of contact centre operations can be improved by using this technology to automate some processes, such as call routing or straightforward customer service exchanges. Improved call centre productivity and cost savings are two of the key advantages of voice recognition-based call centre automation. By automating some processes, call centre employees may concentrate on more difficult or valuable jobs that

demand for human interaction, such resolving customer complaints or offering emotional support [27].

Challenges

Implementing speech recognition is extremely difficult for a number of reasons, including:

- **Data Limitations:** Large volumes of labelled training data are necessary for speech recognition algorithms to reach high accuracy, yet gathering and annotating this data may be time-consuming and expensive.
- **Noisy and unpredictable:** Speech recognition models struggle to correctly identify the intended words in real-world speech because the speech signals are frequently chaotic and unpredictable.
- **Accents and Dialects:** While diverse accents and dialects can cause changes in pronunciation and intonation, speech recognition models may have trouble understanding speech from people who use them.
- **Dataset:** Building a large word bank is one of the key language-dependent issues for a voice recognition system. A database of words is necessary for an ASR system that uses speech-to-word recognition. However, phoneme-based ASR systems are taught using a database of words, but they primarily learn to categorise phonemes. For American and European languages as well as other languages, there are many datasets accessible, although there are few datasets for some languages.

V. FUTURE DIRECTIONS

With an emphasis on increasing accuracy, supporting several languages, and discovering new applications, speech recognition technology is likely to keep improving in the coming. Researchers and developers will need to investigate new methods and models that can manage noisy and changeable settings in addition to gathering more varied and representative training data in order to accomplish these aims. In order to handle many languages and dialects, new language models and training data must be created. Supporting numerous languages and dialects will also need the creation of fresh language models and training materials. Speech recognition technology is also anticipated to find new uses in industries including healthcare, education, and entertainment, thereby altering how people communicate with one another and with technology. Collaboration between researchers, business executives, and governmental groups will be necessary to make these breakthroughs possible.

VI. CONCLUSION

The effectiveness of using Recurrent Neural Networks (RNNs) in speech recognition has the capability to process sequential data and model temporal dependencies makes them suitable for this task. The techniques studied in this research indicate that RNN-based models are superior to conventional methods. However, to improve the accuracy of RNN-based speech recognition models, several challenges need to be addressed, including improving the handling of variable and noisy speech input, reducing computational complexity, and expanding the vocabulary coverage.

ACKNOWLEDGMENT

We would like to thank IIMS Chinchwad, Pune, India for organizing the Third International Conference on "Innovations in Management & Information Technology" (ICIMIT - 2023), Department of Computer Science, Islamic University of Science & Technology, India for providing necessary infrastructure to carry out the work smoothly.

References

- [1] Beysolow, I. I. (2018). What Is Natural Language Processing?. In *Applied Natural Language Processing with Python* (pp. 1-12). Apress, Berkeley, CA.
- [2] Fuad, A., & Al-Yahya, M. (2022). Recent developments in arabic conversational AI: A literature review. *IEEE Access*.
- [3] Mathew, L., & Bindu, V. R. (2020, March). A review of natural language processing techniques for sentiment analysis using pre-trained models. In *2020 Fourth International Conference on Computing Methodologies and Communication (ICCMC)* (pp. 340-345). IEEE.
- [4] Lone, N. A., Giri, K. J., & Bashir, R. (2022). Machine Intelligence for Language Translation from Kashmiri to English. *Journal of Information & Knowledge Management*, 2250074.
- [5] Liu, X., Chen, H., & Xia, W. (2022). Overview of named entity recognition. *Journal of Contemporary Educational Research*, 6(5), 65-68.
- [6] El-Kassas, W. S., Salama, C. R., Rafea, A. A., & Mohamed, H. K. (2021). Automatic text summarization: A comprehensive survey. *Expert systems with applications*, 165, 113679.
- [7] Bhangale, K. B., & Mohanaprasad, K. (2021). A review on speech processing using machine learning paradigm. *International Journal of Speech Technology*, 24(2), 367-388.
- [8] Islam, J., Mubassira, M., Islam, M. R., & Das, A. K. (2019, February). A speech recognition system for Bengali language using recurrent neural network. In

- 2019 IEEE 4th international conference on computer and communication systems (ICCCS) (pp. 73-76). IEEE.
- [9] Mahmood, A., & Utku, K. Ö. S. E. (2021). Speech recognition based on convolutional neural networks and MFCC algorithm. *Advances in Artificial Intelligence Research*, 1(1), 6-12.
- [10] Sherstinsky, A. (2020). Fundamentals of recurrent neural network (RNN) and long short-term memory (LSTM) network. *Physica D: Nonlinear Phenomena*, 404, 132306.
- [11] White, G. M. (1972, December). Mechanical speech recognition for the paralyzed or profoundly deaf. In *Proceedings 1972 Carnahan Conference on Electronic Prosthetics* (pp. 48-51).
- [12] Juang, B. H., & Rabiner, L. R. (2005). *Automatic speech recognition—a brief history of the technology development*. Georgia Institute of Technology. Atlanta Rutgers University and the University of California. Santa Barbara, 1, 67.
- [13] Schuster - Böckler, B., & Bateman, A. (2007). An introduction to hidden Markov models. *Current protocols in bioinformatics*, 18(1), A-3A.
- [14] Rabiner, L., & Juang, B. (1986). An introduction to hidden Markov models. *IEEE ASP Magazine*, 3(1), 4-16.
- [15] Ellermann, C., Even, S. V., Huang, C., & Manganaro, L. (1993). *Dragon Systems' Experiences in Small to Large Vocabulary Multi-Lingual Speech Recognition Applications*. In *Third European Conference on Speech Communication and Technology*.
- [16] Vertanen, K. (2006). Speech and speech recognition during dictation corrections. In *Ninth International Conference on Spoken Language Processing*.
- [17] Heckmann, M., Berthommier, F., & Kroschel, K. (2001). A hybrid ANN/HMM audiovisual speech recognition system. In *AVSP 2001-International Conference on Auditory-Visual Speech Processing*.
- [18] Schalkwyk, J., Beferman, D., Beaufays, F., Byrne, B., Chelba, C., Cohen, M., ... & Strobe, B. (2010). "Your word is my command": Google search by voice: A case study. In *Advances in speech recognition* (pp. 61-90). Springer, Boston, MA.
- [19] Pieraccini, R., & Director, I. C. S. I. (2012). From audrey to siri. Is speech recognition a solved problem, 23.
- [20] Lopatovska, I., Rink, K., Knight, I., Raines, K., Cosenza, K., Williams, H., ... & Martinez, A. (2019). Talk to me: Exploring user interactions with the Amazon Alexa. *Journal of Librarianship and Information Science*, 51(4), 984-997.
- [21] López, G., Quesada, L., & Guerrero, L. A. (2017, July). Alexa vs. Siri vs. Cortana vs. Google Assistant: a comparison of speech-based natural user interfaces. In *International conference on applied human factors and ergonomics* (pp. 241-250). Springer, Cham.
- [22] Hoy, M. B. (2018). Alexa, Siri, Cortana, and more: an introduction to voice assistants. *Medical reference services quarterly*, 37(1), 81-88.
- [23] Li, J., Zhao, R., Hu, H., & Gong, Y. (2019, December). Improving RNN transducer modeling for end-to-end speech recognition. In *2019 IEEE Automatic Speech Recognition and Understanding Workshop (ASRU)* (pp. 114-121). IEEE.
- [24] Iyer, V., Shah, K., Sheth, S., & Devadkar, K. (2020, June). Virtual assistant for the visually impaired. In *2020 5th International Conference on Communication and Electronics Systems (ICCES)* (pp. 1057-1062). IEEE.
- [25] Carter, M., Allison, F., Downs, J., & Gibbs, M. (2015, October). Player identity dissonance and voice interaction in games. In *Proceedings of the 2015 Annual Symposium on Computer-Human Interaction in Play* (pp. 265-269).
- [26] Latif, S., Qadir, J., Qayyum, A., Usama, M., & Younis, S. (2020). Speech technology for healthcare: Opportunities, challenges, and state of the art. *IEEE Reviews in Biomedical Engineering*, 14, 342-356.
- [27] Bojanić, M., Delić, V., & Karpov, A. (2020). Call redistribution for a call center based on speech emotion recognition. *Applied Sciences*, 10(13), 4653.

DEEP LEARNING BASED SMALL OBJECT DETECTION AND ITS APPLICATIONS

Iqra

iqra@iust.ac.in

Kaiser Javeed Giri

kaiserjaveed@gmail.com

Danish Nazir Raja

danish.raja@iust.ac.in

Department of Computer Science Islamic University of Science and Technology
1-University Avenue. Awantipora, Pulwama, Pin -192122 Jammu and Kashmir, India.

ABSTRACT

Object detection is an important and interesting visual recognition problem in the field of Computer Vision (CV) of Artificial Intelligence (AI) in which a computer can perceive or interpret the contents of an image and detect the objects that are present in it. Much of the research has been done in detecting the medium and large-sized objects in images but the detection of smaller objects has gained minimal attention. The detection of smaller objects in images is a difficult task and it is the foundation for many other computer vision tasks, such as image captioning, scene understanding, and so on and it has also been widely used in real-life applications such as robotic vision, autonomous driving, drone scene analysis, military reconnaissance, and surveillance, etc. Although some work has been done in the direction of small object detection, but we have not yet achieved the results that are acceptable in many application domains. Due to the lack of appearance information in small objects, background clutter, viewpoint variation, and partial occlusions, small object detection is still challenging. State-of-the-art object detection algorithms are ineffective in detecting small objects, making their direct implementation in practical applications impossible. However, with certain changes to a given architecture, an acceptable level of detection accuracy can be reached for at least some application areas. These changes are usually the result of learning object representations at different scales, which increases the computational cost. Increased computational expenses combined with low-performance efficiency produce a trade-off situation in which achieving a win-win solution is challenging. Small objects in an image have more probable locations than large objects, thus techniques for properly locating small objects require more precision. Another significant challenge is that prior knowledge on small object detection is limited. In the last several years, there has been a lot of advancement in the field of small object detection. Yet, when it comes to object detection in general and small item detection in particular, there is still a big gap between current state-of-the-art and human-level performance. This proposed research will assist us in figuring out if general object detection models can be tweaked to detect small objects for a particular application.

KEYWORDS - Artificial Intelligence, Computer Vision,

Object Detection, Convolutional Neural Networks, Occlusion, Background Clutter.

I. INTRODUCTION

Small object detection is a significant challenge in the field of computer vision, with widespread practical applications across domains such as surveillance, robotics, autonomous driving, and biomedical imaging. The recognition and detection of small objects such as pedestrians, traffic signs, or cells are particularly challenging due to their small size, low contrast, and occlusion. In numerous real-world scenarios, the ability to detect and track small objects is essential. For example, in surveillance [1], it is crucial to detect and track small objects like humans and vehicles to ensure public safety and security. In robotics [2], small object detection is essential for tasks such as object grasping and manipulation. In biomedical imaging [3], detecting and analysing small objects like cells and microorganisms is vital for disease diagnosis and drug discovery. Recent advances in deep learning techniques have shown significant potential in addressing the challenges of small object detection. Convolutional neural networks (CNNs) [4] have achieved exceptional results in object detection and recognition tasks, including small object detection.

The goal of using deep learning for small object detection is to improve upon the limitations of traditional computer vision methods and achieve more accurate and effective small object detection in real world usage scenarios.

The objectives of the paper includes understanding of the difficulties that arise when detecting small objects in computer vision and the importance of developing detection methods that are both precise and efficient. The paper intends to examine the most advanced deep learning methods for detecting small objects, with particular emphasis on Convolutional Neural Networks. Also, the paper seeks to emphasize the potential research avenues and future directions in the realm of detecting small objects using deep learning techniques.

II. LITERATURE REVIEW

Small object detection has historically been a challenging issue in computer vision due to the intricate visual patterns of small objects and the difficulties they present, such as low contrast and occlusion. However, recent advancements in deep learning, especially Convolutional Neural Networks (CNNs), have shown great promise in addressing these difficulties and achieving accurate detection of small objects.

Over the past decade there has been a substantial growth of research in the area of small object detection through deep learning techniques. Various studies have explored innovative methods and architectures to enhance the accuracy and effectiveness of detection systems. One of the latest methods in this area is the YOLO (You Only Look Once) is a method that was developed by Redmon et al. [5] in 2016 and employs a single CNN to predict both bounding boxes and object classes. Although YOLO is renowned for its quick object detection, its coarse feature maps make it difficult to identify small objects. The YOLO architecture has been updated multiple times, with the latest version being YOLO v8. To address this limitation, researchers have proposed more advanced CNN-based architectures, such as the Single Shot Detector (SSD) by Liu et al. [6] and RetinaNet by Lin et al. [7]. SSD is a single-stage detector that uses multiple feature maps of different resolutions to detect objects of various sizes. RetinaNet employs a focal loss function to achieve cutting-edge performance on a number of small object detection datasets by giving harder examples higher weights and easier ones lower weights. RetinaNet, however, needs a lot of processing power. Another well-liked method for finding tiny objects is the two-stage detector, like the Faster R-CNN architecture by Ren et al. [8], which employs a distinct CNN for classification and a separate RPN to produce region proposals. Faster R-CNN detects small objects with high accuracy, but it is comparatively slow when compared to other methods.

Despite the success of deep learning techniques in small object detection, several challenges remain. One of the main challenges is handling object occlusion [9], which is prevalent in real-world scenarios. Another challenge is handling objects with varying scales [10], as small objects can appear in different sizes, and detecting them at different scales is essential for accurate detection. Identifying and addressing these challenges provide promising research opportunities for improving small object detection using deep learning techniques.

In order to overcome the challenges mentioned, several solutions have been proposed by researchers in recent years. Wang et al. [11] introduced a multi-task learning framework that jointly predicts object locations and occlusion states to enhance the accuracy of small object detection in occluded scenarios. Another approach proposed by Zhang et al. [12] is a scale-aware network that dynamically adjusts the network architecture to handle objects of varying scales. Additionally, some researchers have used attention mechanisms [13] and synthetic data generation [14] to improve small object detection performance. Detecting smaller objects in images and training object detection models is a challenging task. Despite the introduction of various models that perform better in detecting smaller objects, the current performance is still far from that of humans.

III. DEEP LEARNING BASED SMALL OBJECT DETECTION

Convolutional Neural Networks (CNNs) are created with the particular purpose of extracting important features from images through the use of numerous convolutional layers. This makes them well-suited for detecting objects of different sizes and shapes, which is particularly useful for small object detection. Some of the commonly used CNN architectures for small object detection include YOLO, SSD, RetinaNet, and Faster R-CNN.

YOLO employs a fully convolutional neural network to partition the input image into a grid and perform object detection on each grid cell. The YOLO architecture is composed of two parts: a feature extraction network and a detection network as shown in Figure 1.

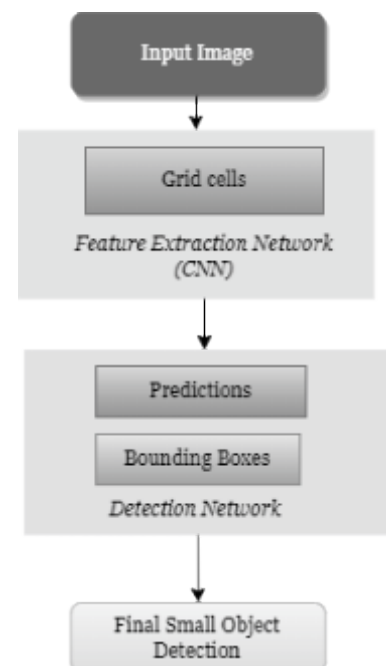

The feature extraction network utilizes Convolutional layers to extract image features that are then fed into the detection network. The detection network is responsible for predicting the class probabilities and bounding boxes for each object in each grid cell. Due to its real-time detection capability and high accuracy, YOLO is highly effective in small object detection. Its single-stage detection process makes it faster than other models like Faster R-CNN, which has a two-stage detection process.

YOLO can also detect multiple objects in a single image, even if they overlap. Despite its advantages, YOLO has a significant drawback in detecting small objects. This is due to the fact that its feature maps are relatively coarse, making it challenging to accurately detect small objects. Moreover, YOLO faces difficulty detecting objects that are highly occluded or have low contrast with the background.

SSD (Single Shot MultiBox Detector) is the object detection algorithm that doesn't require any additional region proposal algorithms. Its architecture is based on a deep convolutional neural network (CNN) as shown in Figure 2, The SSD network comprises a base CNN, such as VGG or ResNet, to extract features from the input image, and a set of auxiliary convolutional layers that detect objects at multiple scales and aspect ratios. To detect objects at different scales and aspect ratios, the SSD network uses pre-defined rectangles, known as default boxes, that are placed at various locations in the input image.

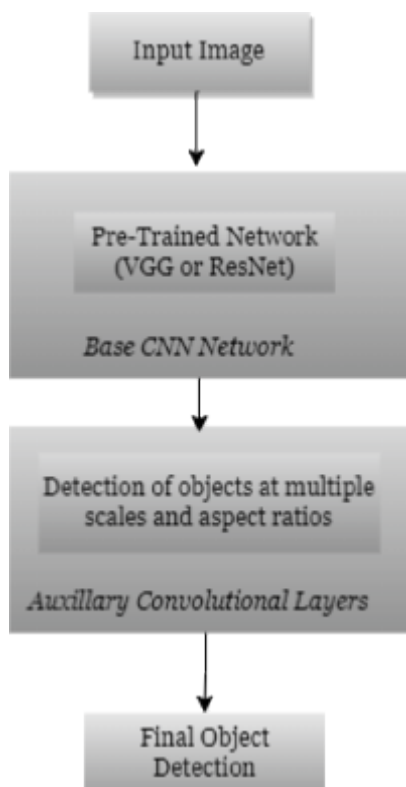

The SSD network predicts the offset and class probabilities for each default box to refine the location of the detected objects. The benefits of SSD include its speed and efficiency, as it can process images in real-time or very close to real-time, and its ability to identify small objects in images using multiple convolutional layers at various scales. However, it may have difficulty detecting objects that are partially occluded or have complex shapes, and its performance can be affected by the quality and resolution of the input image as well as the choice of default box sizes and aspect ratios.

RetinaNet is a deep convolutional neural network (CNN) based object detection method that is intended to find objects of various sizes and aspect ratios, including small objects that can be difficult to find using other algorithms. The RetinaNet architecture comprises a backbone network, a feature pyramid network (FPN), and two task-specific subnetworks for classification and box regression. The backbone network extracts features from the input image, while the FPN generates feature maps of different scales to detect objects of varying sizes. RetinaNet's feature fusion strategy combines the feature maps generated by the FPN to improve object detection accuracy. The classification subnet predicts the probability of an object belonging to a specific class, while the box regression subnet predicts the coordinates of a bounding box around the object. RetinaNet employs a focal loss function, which assigns higher weights to misclassified examples that are difficult to classify, while ignoring easy examples. This helps the model to focus on learning how to detect difficult examples, such as small objects, while ignoring easier examples.

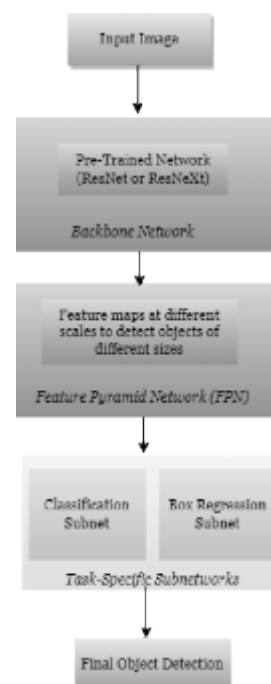

RetinaNet's ability to detect small objects in an image is one of its advantages. Its high accuracy is achieved through a multi-scale feature fusion strategy and the focal loss function, making it suitable for applications such as autonomous driving and surveillance. RetinaNet's deep neural network architecture can be computationally expensive, limiting its applicability in certain scenarios. Additionally, it may struggle with detecting partially occluded objects or objects with complex shapes, which can affect its overall performance. Figure 3, shows the concept.

Faster R-CNN Faster R-CNN is an advanced object detection algorithm that utilizes a deep convolutional neural network to locate objects within an image. Its architecture comprises three key components, namely the Region Proposal Network (RPN), the backbone network, and the Fast R-CNN as shown in Figure 4. The RPN generates object proposals within an image, while the backbone network extracts feature maps from the input image. The object proposals produced by the RPN are categorised by the Fast R-CNN network. Because faster R-CNN uses anchor boxes with various scales and aspect ratios in the RPN to capture objects of various sizes, it is particularly effective at identifying small objects.

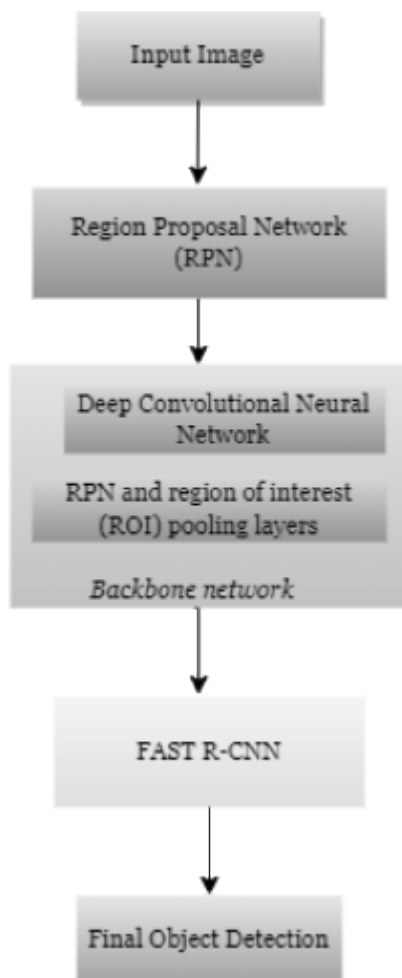

However, the algorithm has certain limitations. The training process for Faster R-CNN can be time-consuming and requires a significant amount of labeled data. The accuracy of Faster R-CNN may be affected by the size and quality of the object proposals generated by the RPN, and it may struggle with detecting objects in complex scenes with occlusions and clutter.

The Table I, outlines advantages and disadvantages of each technique,

TABLE TECHNIQUES OF DETECTING OBJECTS

Technique	Advantages	Disadvantages
YOLO	Real-time detection capability and high accuracy.	faces difficulty detecting objects that are highly occluded or have low contrast with the background
SSD	Process images in real-time or near - real-time.	Difficulty detecting partially occluded objects.
RetinaNet	Ability to detect small objects in an image, high accuracy through a multi-scale feature fusion strategy and the focal loss function.	Computationally expensive.
Faster R-CNN	Accuracy is high	Time-consuming training process

I. APPLICATIONS AND CHALLENGES

The task of small object detection in computer vision has numerous significant applications in many different disciplines. The applications and challenges have been discussed here in this section.

Applications - Small object detection using deep learning finds its use in multiple fields, some of which include:

- A. Medical Imaging: The identification of small objects in medical images [15] using deep learning can be beneficial in early disease detection and treatment, such as detecting small abnormalities like tumors, microaneurysms, or lesions.
- B. Surveillance: Small object detection has the potential to aid in identifying and tracking objects or individuals of interest in complex and cluttered scenes in surveillance applications, such as security, traffic monitoring, or wildlife observation.
- C. Robotics: The use of small object detection can enhance the capability of robots [16] to detect and manipulate small objects with higher precision and accuracy. In industrial applications, such as the assembly or sorting of small parts, this can be advantageous.
- D. Autonomous driving: The detection of small objects

like cyclists or pedestrians is critical for the safety of autonomous vehicles [17], preventing accidents, and ensuring smooth navigation through complex environments. Small object detection aids in identifying and avoiding potential collisions.

- E. Agriculture: Small object detection is an effective method for monitoring crops [18] by detecting pests and diseases early on. By providing early detection, farmers can take preventive measures to mitigate crop damage and increase their yield.

Challenges - Detecting small objects using deep learning presents significant challenges due to a variety of factors as:

- The limited availability of data is a significant challenge for small object detection using deep learning. Due to their rarity and difficulty in labeling, there may be insufficient data available for training deep learning models. As a result, overfitting can occur, leading to reduced generalization performance.
- Small objects frequently have low contrast with their surroundings, which can make it challenging to distinguish them from the background.
- Small objects can appear in varying scales, rotations, and orientations, which can make it difficult for deep learning models to detect them accurately in different contexts.
- Partial or full occlusion of small objects by other objects presents a challenge for deep learning models to accurately detect them.
- Small object detection can be hindered by class imbalance, where smaller objects are significantly outnumbered by larger ones within an image. This can lead to reduced performance in detecting smaller objects.

To overcome these challenges [19], it is necessary to explore innovative deep learning architectures, optimize data augmentation techniques, create reliable training algorithms and use domain-specific expertise to improve the performance of small object detection.

II. FUTURE DIRECTIONS

To improve the detection precision of deep learning models for small objects, Numerous potential study directions can be investigated. These could include exploring transfer learning techniques to adapt pre-existing models trained on larger objects for small object detection, examining multi-scale approaches to detect small objects across different scales and resolutions, utilizing attention mechanisms to emphasize small objects and their features, applying semi-supervised learning techniques to leverage unlabeled data, designing innovative architectures specifically tailored to small object detection that

integrate domain-specific knowledge, and improving adversarial robustness to ensure models can maintain their accuracy in security-critical applications. By pursuing these research directions, Deep learning may make it possible to overcome the difficulties connected with small object detection and notably improve the detection accuracy of deep learning models.

III. CONCLUSION

The task of detecting small objects using deep learning presents several challenges due to factors such as limited data, low contrast, variable scale, and occlusion. However, the need for accurate detection of small objects in various applications such as surveillance, robotics, and autonomous vehicles demands further improvement in the detection accuracy of deep learning models. To achieve this, future research can be directed towards exploring transfer learning [20], multi-scale approaches, attention mechanisms, semi-supervised learning [21], novel architectures, and adversarial robustness [22]. By addressing these challenges, the detection accuracy of deep learning models in small object detection can be significantly enhanced, leading to the development of more efficient and effective systems with a wide range of potential applications.

ACKNOWLEDGMENT

We would like to thank IIMS Chinchwad, Pune, India for organizing the Third International Conference on "Innovations in Management & Information Technology" (ICIMIT - 2023), Department of Computer Science, Islamic University of Science & Technology, India and DST -INSPIRE, Govt. of India for providing necessary infrastructure to carry out the work smoothly.

References

- [1] Jha, S., Seo, C., Yang, E., & Joshi, G. P. (2021). Real time object detection and tracking system for video surveillance system. *Multimedia Tools and Applications*, 80, 3981-3996.
- [2] Xu, G., Khan, A. S., Moshayedi, A. J., Zhang, X., & Shuxin, Y. (2022). The Object Detection, Perspective and Obstacles In Robotic: A Review. *EAI Endorsed Transactions on AI and Robotics*, 1(1).
- [3] Wu, L. (2019). Biomedical image segmentation and object detection using deep convolutional neural networks (Doctoral dissertation, Purdue University Graduate School).
- [4] Liu, Y., Sun, P., Wergeles, N., & Shang, Y. (2021). A survey and performance evaluation of deep learning methods for small object detection. *Expert Systems with Applications*, 172, 114602.
- [5] Redmon, J., Divvala, S., Girshick, R., & Farhadi, A. (2016). You only look once: Unified, real-time object

- detection. In Proceedings of the IEEE conference on computer vision and pattern recognition (pp. 779-788).
- [6] Liu, W., Anguelov, D., Erhan, D., Szegedy, C., Reed, S., Fu, C. Y., & Berg, A. C. (2016). Ssd: Single shot multibox detector. In *Computer Vision–ECCV 2016: 14th European Conference, Amsterdam, The Netherlands, October 11–14, 2016, Proceedings, Part I 14* (pp. 21-37). Springer International Publishing.
- [7] Lin, T. Y., Goyal, P., Girshick, R., He, K., & Dollár, P. (2017). Focal loss for dense object detection. In Proceedings of the IEEE international conference on computer vision (pp. 2980-2988).
- [8] Ren, S., He, K., Girshick, R., & Sun, J. (2015). Faster r-cnn: Towards real-time object detection with region proposal networks. *Advances in neural information processing systems*, 28.
- [9] Saleh, K., Szénási, S., & Vámosy, Z. (2021, January). Occlusion handling in generic object detection: A review. In *2021 IEEE 19th World Symposium on Applied Machine Intelligence and Informatics (SAMI)* (pp. 000477-000484). IEEE.
- [10] Zou, Z., Chen, K., Shi, Z., Guo, Y., & Ye, J. (2023). Object detection in 20 years: A survey. *Proceedings of the IEEE*.
- [11] Zhao, S., Liu, T., Zhao, S., & Wang, F. (2019, July). A neural multi-task learning framework to jointly model medical named entity recognition and normalization. In *Proceedings of the AAAI Conference on Artificial Intelligence* (Vol. 33, No. 01, pp. 817-824).
- [12] Li, Y., Chen, Y., Wang, N., & Zhang, Z. (2019). Scale-aware trident networks for object detection. In *Proceedings of the IEEE/CVF international conference on computer vision* (pp. 6054-6063).
- [13] Yan, C., Tu, Y., Wang, X., Zhang, Y., Hao, X., Zhang, Y., & Dai, Q. (2019). STAT: Spatial-temporal attention mechanism for video captioning. *IEEE transactions on multimedia*, 22(1), 229-241.
- [14] Abay, N. C., Zhou, Y., Kantarcioglu, M., Thuraisingham, B., & Sweeney, L. (2019). Privacy preserving synthetic data release using deep learning. In *Machine Learning and Knowledge Discovery in Databases: European Conference, ECML PKDD 2018, Dublin, Ireland, September 10–14, 2018, Proceedings, Part I 18* (pp. 510-526). Springer International Publishing.
- [15] Li, Z., Dong, M., Wen, S., Hu, X., Zhou, P., & Zeng, Z. (2019). CLU-CNNs: Object detection for medical images. *Neurocomputing*, 350, 53-59.
- [16] Coates, A., & Ng, A. Y. (2010, May). Multi-camera object detection for robotics. In *2010 IEEE International Conference on Robotics and Automation* (pp. 412-419). IEEE.
- [17] Cai, Y., Luan, T., Gao, H., Wang, H., Chen, L., Li, Y., ... & Li, Z. (2021). YOLOv4-5D: An effective and efficient object detector for autonomous driving. *IEEE Transactions on Instrumentation and Measurement*, 70, 1-13.
- [18] Storey, G., Meng, Q., & Li, B. (2022). Leaf disease segmentation and detection in apple orchards for precise smart spraying in sustainable agriculture. *Sustainability*, 14(3), 1458.
- [19] Tong, K., & Wu, Y. (2022). Deep learning-based detection from the perspective of small or tiny objects: A survey. *Image and Vision Computing*, 104471.
- [20] Yang, Z., Yu, W., Liang, P., Guo, H., Xia, L., Zhang, F., ... & Ma, J. (2019). Deep transfer learning for military object recognition under small training set condition. *Neural Computing and Applications*, 31, 6469-6478.
- [21] Sohn, K., Zhang, Z., Li, C. L., Zhang, H., Lee, C. Y., & Pfister, T. (2020). A simple semi-supervised learning framework for object detection. *arXiv preprint arXiv:2005.04757*.
- [22] Saha, A., Subramanya, A., Patil, K., & Pirsivash, H. (2020). Role of spatial context in adversarial robustness for object detection. In *Proceedings of the IEEE/CVF Conference on Computer Vision and Pattern Recognition Workshops* (pp. 784-785).

FINANCING OF BUSINESS

SANJAY AGHAV

Asst.Professor at Senior College,
P. Jog College of Science & Commerce,
Mayur Colony, Kothrud - Pune-38.

This paper has been divided into three parts Viz.

1 Money

2. Financing of Business

3. Current Business and Finance.

Part I: MONEY

Introduction:- Finance means management of money and it is the most important factor for every business. Money is a basic requirement of every business activity irrespective of its size hence the study of finance is most important for all types of business. The object of every business is to earn profit and wealth accumulation and all it works through money. Therefore study of money and finance is not only important to business but it is the main object of every business.

Before studying Finance it is necessary to study money. Every economy in the world uses money for their day to day transactions. Money may be called and named differently but in all types of economy money is used for exchange of goods and services.

Meaning :

Exchange of goods and services are measured in terms of money. Money is a unit for calculating the value of particular goods and services. Every business has carried through either selling goods or services and such exchange is measured in terms of money. Money is unit of measure as well as used for every economic activity.

Human activities are divided into economic and non economic activities. Every person has to work for day to day life and has to do some economic activity without that it is impossible to survive. Economic activities are counted in terms of money whether it is Salary for service provided, profit earned from business and specialized professions services like doctors, lawyers or any other independent economic activity.

It means every human being is working for money. As all human economic activities are to be paid or received in terms of money. Human needs are endless and every rational person is trying to satisfy his own needs throughout life one after another. It means every human being is trying to earn money to satisfy their own needs in terms of money.

History of Money :

1. **Barter Money System** : In the primitive stage of civilization human beings use different goods and things are used as money for example Grain for Grain, Animals for Animals etc.
2. **Commodity Money System** : After the barter system different commodities and metals were used as money for day to day transactions. As the difficulty of counting and measurement and storage of barter system commodities are used like metals are used as money for measurement of transactions.
3. **Metal Money System** : Due to different commodities and its problems of valuation one single metal system started to be used as money. The precious metals like silver and gold coins are used as money.
4. **Paper Money**: Due to scarcity of gold and an increase in the volume of transactions Gold is used as standard for paper money and papers like bills, receipts and printed cheques as well as notes are used as money.
5. **Representative Money System**: In the 20th century Banking system developed its own monetary system as representative money in terms of Bills of exchange, Cheques etc. and in many countries the Government has given authority to its central bank to print notes on behalf of the Government.
6. **Plastic Money System**: By the end of 20th century and beginning of 21st century technology has taken tremendous change in human life and with the help of electronic mode of transactions plastic money like debit and credit cards are used as money without carrying hard cash or notes.
7. **Electronic Money System**: Due to vast use of computers and mobile as a new way of communication electronic money is used as money for day today transactions. Online payment and electronic transactions has taken a huge volume of transactions as well as fast mode of transaction electronic money is used worldwide.

FUNCTIONS OF MONEY:

Money is generally accepted as a medium of exchange that is payment of goods and services, payments of debts such as taxes in a particular country & socio-economic context. The primary functions of money which distinguish money are medium of exchange, a unit of accounts, a store of value and something a standard of deferred payment.

Definitions:-

1. Money, A commodity accepted by general consent as a medium of exchange
2. "Money is what money Does" Functions of money can be divided into two parts viz. Primary Functions and Secondary Functions.

A. Primary Functions of Money:-

1. Medium of Exchange:- The most important and primary function of money is it used as medium of exchange. Any commodity or service is purchased or sold in terms of money.
2. Measure of Value:- Every service and commodity is expressed in terms of money. The price and value of each and every service and goods are expressed in terms of money in all over the economic systems. Whether it is Dollars, Pounds, Euro or Rupees.

B. Secondary Functions of Money:

1. Standard of Deferred Payment :- Payment in future is called deferred payment. It was very difficult in the barter system to make payments in the future as animals, grains become old and not usable in the future.
2. Store of Value:- In barter system it was very difficult to store the money in the form of Animals, grains, metals etc. this difficulty is overcome by money. as it needs a very small place and can also be stored in a bank too.
3. Transfer of Value:- Money can be easily transferred from one place to another as it can be easily converted in small to big denomination and it can carry or it can be transferred through banks. The immovable property also can be transferred through money from one place to another place by selling and purchasing in the form of money.

C. Other Functions:

1. Basis of credit : Commercial banks create credit money on the basis of money deposited in the banks by their customers. Money provides the liquid base for credit money.
2. Measurement of National Income:- National income is also counted in terms of money all the four factors of

production are paid in form of money as Rent, Wages, Interest and Profit.

3. Liquidity to wealth:- Money is called the most liquid asset as money can be easily converted into an asset and vice-versa.
4. Macro Economic Variables:- Gross National Product, National Income, Total saving, Total Investments also estimated in terms of money as well as Government taxes are also counted and expressed in terms of money.

Qualities of Good Money:-

1. General Acceptability:- The money must be generally accepted by the public in large as it should be cognizable, portable, countable etc.
2. Durability:- The life of money should be long as it is handled many times as well as many peoples.
3. Divisibility:- Money should be easily divisible in small as well as big denominations as and when it is required.
4. Portable:- Money should be easily transferred from one place to another.
5. Cognizable:- Money should be easily recognized by all categories of people as small, Big, Old aged, educated as well as non educated too

Part II : FINANCING OF BUSINESS**FINANCE = Management of Money (Sources & Application)****Introduction:-**

Every business aims at maximization of profit & accumulation of wealth through its activities. All business activities are measured in terms of money and money's worth. It is the most important factor of production as well as services provided in auxiliary to business. Every business needs money as and when required money is the bloodline of business. Without money business cannot work successfully.

The role of finance has been increased nowadays as every business has to work in competitive and dynamic situations. Only financial accounting is not enough to control and manage the business but cost accounting and management accounting techniques also emerged to increase the efficiency and internal controls. Finance is the most important and effective process for all types of business.

Meaning:-

Finance means management of money that is a source of

money and application of money. Every business needs timely money in such a way that shortage of money should be arranged in time and excess money should be properly invested in such a way that will give maximum return.

It should be noted that not only shortage of money will downfall the business activities but excess circulation of money in business also causes adverse affect on business. Hence proper management of money in all types of business is most important for smooth working of business activities.

The need and requirement of finance depends on the size of the business as well as its growth and expansion plans. Modern businesses are working in a dynamic situation where the world becomes a market and to survive in such a cut throat competition one needs to keep very uptodate and focused to minimize the financial risk. The need of finance, its sources and management of money is totally different to every business according to the size of business.

Different Forms of Business and Finance :-

After independence, The Government of India has accepted a mixed pattern of economy hence the Public and Private sector co-exist and work hand in hand. The scope of private sectors has been increased after the new economic policy in 1991.

1. Proprietary Concerns : This is a basic form of business and it works in local areas. The capacity of business is small and its capital requirement is also limited. Following are the ways that such businesses can source their funds.

- 1. Savings
- 2. Borrowed from Friends and Relatives
- 3. Bank Loans

2. Undivided Family Business: This type of business is only working in India only the sources of funds are in the same of proprietary concern or most of the proprietary concerns are the extended forms of Family business.

3. Partnership Business: This type of business is an extended form of proprietary concern and family business. No of members in partnership has been increased by 2013 Companies Act 2013 from 20 to 50. It will help to increase the size of capital as well as business capacity.

4. Private Companies: This type of business are working under corporate sector and enjoying different finance facilities as well as extended form of business over partnership. A per Companies Act 2013 the no of maximum members has been increased from 50 to 200.

5. Limited Companies : This is the highest form of business which can carry its business activities all over the world. This form of business has huge capital

capacity and can raise capital from the open market with different market derivatives like Shares, Debentures, Public Deposits, Loans etc.

6. OPC (One Person Company) : This form of business has been coined in new Company Act 2013 to develop and increase the scope of entrepreneurship. Limited liability is the most important feature of this form of business so one can work without the burden of unlimited liabilities

Finance of Corporate Sector:

Sources of Finance

Short Term	Long Term
1. Trade Credit	1. Share Capital
2. Bank Credit	2. Debentures
3. Bank Financing of Accounts Receivable	3. Public Deposits
4. Factoring	4. Saving From NRI
5. Bank Financing of Inventory	5. Lease Financing
6. Working Capital Financing	

FIXED AND WORKING CAPITALS:

Every business organization needs money as per its size of business. Proprietary concern needs less capital compared to Partnership Firm, Private Companies as well as Public limited companies. As the business grows the format of business also changes. It will be a wise decision to change the format of business when the business grows. Every business organization needs funds for its day to day business as well as to run the business for a long life.

The funds required to run the business for a long life are called fixed capital. Such as purchase of Building, Plant and Machinery, Furniture are called capital expenditure as well as fixed capital and where as funds required for running the day to day business is called working capital such as purchase of Material, Payment of Salary and Wages, Rent, Electricity Bills etc. is called working capital.

Factors affecting Capital Requirement

Working Capital	Fixed Capital
1. Nature of Business : Mfg/Trading /Service	1. Nature of Business: Mfg./ Trading / Service
2. Size : Small/ Medium/Large	2. Size : Small/ Medium/Large
3. Business Cycles (Machine/Labour)	3. Technique of Production
4. Seasonal Fluctuations	4. Technology
5. Operational Efficiency	5. Growth / Diversification
6. Credit Allowed	6. Availability of Finance
7. Credit Avail	7. Collaboration / Joint Venture

Financial Budgets and Techniques:-

Every business organization nowadays prepares its financial budgets and uses different techniques for capital budgeting. Some of the common such statements and techniques are given below.

1) Determination of Working Capital:

Particular	Amount (Rs.)
1. Estimation of Current Assets:	
a. Cash and Bank Balance	
b. Inventories	
(i) Raw Material	
(ii) Work in Process	
(iii) Finish Goods	
c. Debtors	
Total Current Assets	
2. Estimation of Liabilities	
a. Creditors	
b. Wages	
c. Overheads	
Total Current Liabilities	
Working Capital Requirement (1-2)	

2) Capital Budgeting Techniques

Traditional / Non-Discounting	Time adjusted or Discounted Cash Flow
a. Payback Period	a. Net Present Value
b. Accounting Rate of Return	b. Profitability Index
	c. Terminal Value
	d. Discounted Payback
	e. Internal Rate of Return

3) Ratio Analysis

Earning Ratios	Balance Ratios
1. Gross Profit Ratio	1. Current Ratio
2. Net Profit Ratio	2. Liquidity Ratio
3. Return on Assets	3. Debt Equity Ratio
4. Return on Equity	4. Debtors Turnover
5. Earning	5. Fixed Assets Turnover
	6. Total Assets Turnover

4) Budgets

Functional Budget	Financial Budget
1. Sales Budget	1. Capital Expenditure Budget
2. Production Budget	2. Research and Development Budget
3. Production Cost Budget	3. Cash Budget
4. Administrative Expense Budget	4. Working Capital Budget
5. Budgeted Income Statement	

5) Marginal Cost Statement

	Amount (Rs.)
Sales	
Less: Variable Cost	
Contribution	
Less: Fixed Cost	
Profit	
Contribution Per Unit	

WHY BUSINESS WENT INTO FINANCIAL CRISES:

1. Competition:- Competition is part and parcel of every business and organization but the way of competition is cut-throat. Then one has to be alert not to involve such Competition but to compete ourselves to better performance otherwise it will affect our own business.
2. Comparison :- Comparing one's own performance with others is one of the ways for self devaluation as it creates unnecessary fear in the minds of the self conscious.
3. Lack of Conservatism :- It is always best to have provisions for the future but not carelessness as in good days it is a wise decision to invest for the future and not to spend in view of more money will come in future.
4. Consolidation:- some of the businesses try to consolidate with similar types of business for a better future but this leads to dismissing self identity.
5. Coalition:- Some businesses try to make syndicates to destroy the rivals but it leads to their own identity as well as ethical grounds of business policies.
6. Comfort Zone:- After some sort of success it is normal to have a comfort zone which leads to synchronization of business activities which again leads to financial crises.
7. Formatting :- As business grows the format of business needs to change otherwise over capitalization leads to financial crisis.
8. IQ V/s EQ V/s SQ :- Only having intelligence is not enough to have success as an entrepreneur but it should maintain emotional as well as social awareness too.
9. Innovation :- Change is the rule of nature and innovation is the need of business hence every business has to innovate for products and services accordingly. Nokia V/s Samsung case.
10. Dynamism :- Business is a dynamic process internal and external changes are inevitable and according to such changes business needs to accept and adopt it.

Part III :- Current Business and Finance

Finance is always a challenging job to its manager whether it is individual capacity or manager of any organizations it may be profit making or non profit making organization. Unlimited wants and limited means and its choices make it a complicated job. As an individual capacity every person

has to look after its dependents needs whereas in organizational capacity it has to manage it within four corners of its working area.

As an entrepreneur or working in the corporate world knowledge of finance is a basic need for everyone. Current world of finance is dynamic as well as supported by technology. Due to modern technology business has been changed in tremendous ways with new ideas of business and new platforms for business such as online business and globalization given a new dimension to business.

Need of finance and financial institutions also increased as well. Government role is not a laissez- faire but as a driving seat for the business world. Business needs for finance can be fulfilled by private financial institutions as well as public financial institutions. In the private sector no of commercial banks and non banking financial institutions are fulfilling the financial needs of business. Quick loan facility is one of the best deals in finance today with in 24 houses online loans are provided nowadays. The online checking of

documentation and linking of Aadhar cards with Pan makes it easy to check the credibility of the borrower and provides quick finance to businesses.

LPG-1991:- Opens the economy of India to the world as well as Indian business have new platforms of business and increased business new opportunities. The need for finance also changed accordingly. The way of quick online business has been supported by new technology in a quick manner.

Make in India:- This new concept has been introduced in 2014 due to globalization and to cope with world competition as well as to make the world familiar with Indian products.

Start up:- Start up India is an initiative of the government of India. The action plan of this initiative is focussing on three areas Simplification, Handholding, Funding support and incentives.

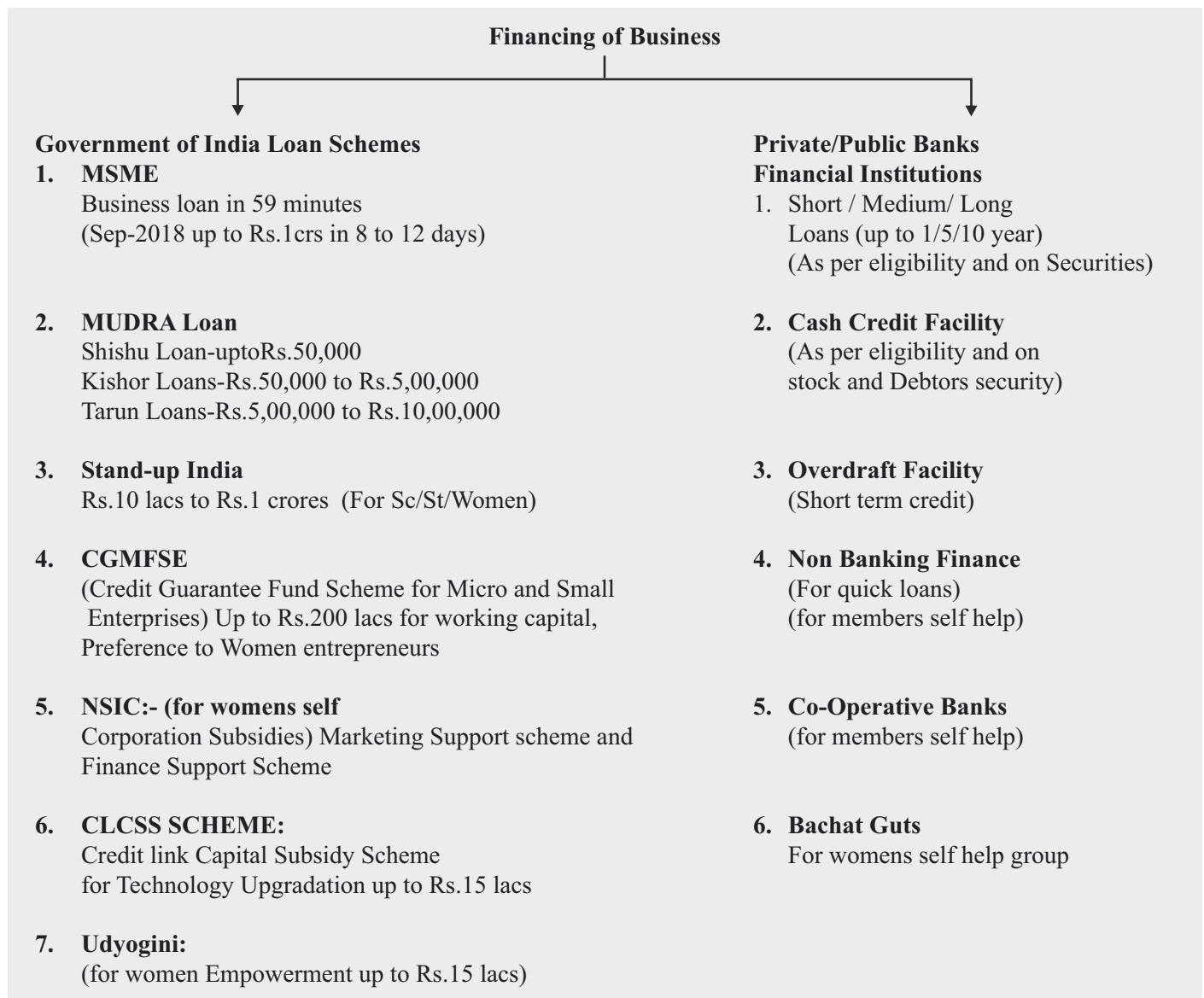

Practical use of the Study:- This study paper is a little overview of money and its development over the time as well as use of different modes of money for human transactions. The history of Money shows that whatever the time and means of exchanging, money is the most important part of our life as a medium of exchange.

The scarcity increases its importance as well as implications and use. The person who uses it wisely in personal capacity, Proprietorship, medium type of business and corporate life as well as all types of non- commercial organization proves that the best use of finance is the indicator of success.

Conclusion:- Financial Management is most important for every business irrespective of its size. There are no opportunities for trial and error methods for financial decisions. It is a deliberate thinking process for every organization. The business is said to be successful only when it follows an ethical way of business as well as assuming the social responsibilities.

References:

1. <https://en.wikipedia.org/wiki/Arthashastra> (Dt. 13 Feb. 2023)
2. <https://en.wikipedia.org/wiki/Money> (Dt. 13 Feb. 2023)
3. <https://www.lendingkart.com/blog/government-loan-schemes-for-small-businesses/>
4. Financial Management: P. V. Kulkarni, B. G. Satyaprasad. Himalaya Publication House, Mumbai. 2015.
5. Financial Management: Text, Problems and Cases. M. Y. Khan and P. K. Jain. Tata McGraw Hill Education Private Ltd. New Delhi. 2010.
6. Financial Management: Theory, Concepts and Problems. Dr. R. P. Rustagi. Taxmann Publication Pvt. Ltd, New Delhi. 2011.
7. Financial Management: Theory and Practice. Prasanna Chandra. McGraw Hill Education India Pvt. Ltd, Chennai. 2019
8. Cost Accounting: Text, Problems and Cases. Jawahar Lal, Seema Srivastava, Manisha Singh. McGraw Hill Education India Pvt. Ltd. Chennai. 2019.
9. Accounting for Management. T Vijayakumar Tata McGraw Hill Education Pvt. Ltd., New Delhi. 2010



DATA VISUALIZATION CONCEPT OF DATA SCIENCE

Mrs. Smita Shashikant Patil (B.Sc. Comp & MCA)

Asst. Teacher, Computer Science,
Deccan Education society's NES & Jr.College Ramanbaug, Pune, India

Abstract: In abstract data science, data is treated as a mathematical object and is analyzed using various mathematical methods such as linear algebra, graph theory, and optimization. It involves developing algorithms and techniques for data analysis that are based on mathematical principles and can be applied to a wide range of datasets.

Overall, abstract data science plays a crucial role in the development of advanced data analysis techniques that can help organizations make better decisions based on the insights gained from their data.

Keyword :

Big Data, Machine Learning, Data Mining, Data Visualization, Predictive Analytics, Artificial Intelligence, Statistical, Natural Language Processing, Deep Learning, Business Intelligence, Data Warehousing, Data Engineering, Exploratory Data Analysis, Time Series Analysis, Dimensionality Reduction, Regression Analysis, Clustering, Classification, Computer Vision, Internet of Things (IoT)

Introduction of Data Science:

Data science is a rapidly growing interdisciplinary field that involves the extraction of insights and knowledge from large and complex datasets using statistical, computational, and mathematical techniques. It encompasses a range of different disciplines, including statistics, machine learning, data mining, and data visualization.

Data science is a process that involves collecting, processing, analyzing, and interpreting data to gain insights and knowledge. The process involves several steps, including data collection, data cleaning and pre-processing, exploratory data analysis, feature engineering, model building, and model evaluation.

Introduction of Data Visualization :

Data visualization techniques are used in various fields, including business, science, finance, healthcare, and many others. The use of data visualization tools allows for a deeper understanding of trends, relationships, and patterns in large sets of data.

Important of Data visualization:

Data visualization is an essential component of data science that helps to make complex data more accessible and understandable. It involves the use of graphical and visual representations to present data in a way that is easy to

interpret and analyze. Data visualization can help to reveal patterns, trends, and relationships that may not be apparent in raw data, making it a powerful tool for data analysis.

Here are some key reasons why data visualization is important in data science:

- 1. Enhances understanding:** Data visualization can help to simplify complex data by presenting it in a way that is easy to understand. By presenting data in a visual form, it becomes easier to identify patterns and relationships, which can help to inform decision-making.
- 2. Communicates information effectively:** Data visualization can help to convey information more effectively than written or numerical data. It can communicate complex data in a way that is easy to understand, making it an effective tool for presenting information to non-technical stakeholders.
- 3. Facilitates exploration:** Data visualization can help to facilitate exploration of data by enabling users to interact with and manipulate the data. This can help to uncover insights and patterns that may not be apparent in raw data.
- 4. Provides insights:** Data visualization can help to reveal insights and patterns that may not be apparent in raw data. By presenting data in a visual form, it can help to identify correlations and relationships, which can help to inform decision-making.

Data Visualization Tools: There are many data visualization tools available that can help data scientists to create effective and informative visualizations of data. Here are some popular data visualization tools:

- 1. Tableau:** Tableau is a widely used data visualization tool that allows users to create interactive visualizations and dashboards using a drag-and-drop interface. It supports a wide range of data sources and has a large user community.
- 2. Power BI:** Power BI is a business intelligence platform that includes data visualization tools. It allows users to create interactive visualizations and reports, and it integrates well with other Microsoft products.
- 3. D3.js:** D3.js is a JavaScript library that allows users to

create custom visualizations using web technologies such as HTML, SVG, and CSS. It provides a high degree of control and customization, making it popular for creating complex and interactive visualizations.

4. **Python Visualization Libraries:** Python has several powerful visualization libraries such as Matplotlib, Seaborn, and Plotly. These libraries allow users to create a wide range of visualizations, from basic charts to complex plots.
5. **QlikView:** QlikView is a data discovery platform that includes data visualization tools. It allows users to create interactive dashboards and reports, and it supports a wide range of data sources.
6. **Google Data Studio:** Google Data Studio is a cloud-based data visualization tool that allows users to create interactive reports and dashboards using a drag-and-drop interface. It integrates well with other Google products and services.

Types Data Visualization: There are several types of data visualizations that can be used to represent and analyze data effectively. The choice of visualization type will depend on the nature of the data and the insights that need to be communicated. Here are some common types of data visualizations:

1. **Line charts:** Line charts are used to show trends over time, such as stock prices or weather patterns. They are created by plotting data points on a graph and connecting them with a line.
2. **Bar charts:** Bar charts are used to compare the values of different categories or groups. They consist of bars of varying lengths, with the height of each bar representing the value of a category.
3. **Scatter plots:** Scatter plots are used to show the relationship between two variables. They consist of points on a graph, with each point representing a combination of values for the two variables.
4. **Heat maps:** Heat maps are used to represent data as a matrix of colors. They are often used to show the distribution of values across a geographic area or to visualize patterns in large datasets.
5. **Tree maps:** Tree maps are used to represent hierarchical data as a set of nested rectangles. They are often used to visualize the distribution of resources or to show the structure of a website.
6. **Pie charts:** Pie charts are used to show the composition of a whole in terms of its parts. They consist of slices of a circle, with each slice representing a proportion of the whole.

7. **Histograms:** Histograms are used to show the distribution of data within a range of values. They consist of bars of varying heights, with the height of each bar representing the number of data points within a certain range.

Data Visualization Techniques in Data Science:-

Some of the main data visualization techniques in data science are univariate analysis, bivariate analysis and multivariate analysis

1. **Univariate Analysis:** In univariate analysis, as the name suggest, we analyze only one variable at a time. In other words, we analyze each variable separately. Bar charts, pie charts, box plots and histograms are common examples of univariate data visualization. Bar charts and pie charts are created for categorical variables, while box plots and histograms are created for numerical variables.
2. **Bivariate Analysis:** In bivariate analysis, we analyze two variables at a time. Often, we see whether there is a relationship between the two variables. The scatter plot is a classic example of bivariate data visualization.
3. **Multivariate Analysis:** In multivariate analysis, we analyze more than two variables simultaneously. The heatmap is a classic example of multivariate data visualization. Other examples are cluster analysis and principal component analysis (PCA).

Advantages and Disadvantages of Data Visualization

Advantages :

There are many advantages of data visualization. Data visualization is used to:

1. Communicate your results or findings with your audience
2. Tune hyper parameters
3. Identify trends, patterns and correlations between variables
4. Monitor the model's performance
5. Clean data
6. Validate the model's assumptions

Disadvantages:

There are also some disadvantages of data visualization.

1. We need to download, install and configure software and open-source libraries. The process will be difficult and timeconsuming for beginners.
2. Some data visualization tools are not available for free. We need to pay for those.
3. When we summarize the data, we'll lose the exact information.

Examples of Data Visualization in Data Science Here are some popular data visualization examples.

1. Weather reports: Maps and other plot types are commonly used in weather reports.
2. Internet websites: Social media analytics websites such as Social Blade and Google Analytics use data visualization techniques to analyze and compare the performance of websites.
3. Astronomy: NASA uses advanced data visualization techniques in its reports and presentations.
4. Geography :
5. Gaming industry:-

Data Visualization Best Practices

1. Set the context

We need to develop a research question that could be solved with a data-driven approach.

2. Know your audience

This is very important as the visualizations depend on the type of audience you have. To present your findings to a business people audience, you need to create visualizations closely related to money, profits, and revenue the terms that business people are familiar with!

3. Choose an effective visual

You need to create the right plot that addresses your requirement. To see the correlations between multiple variables, you can create histograms for each pair of variables. But that is not very effective. Instead, you can create a heatmap that is an effective way of visualizing correlations. When you have many categories, the pie chart is not suitable. Instead, you can create a bar chart. These are some examples of choosing an effective visual for your requirements.

4. Keep it simple

Simple plots are easily readable. We can remove unnecessary backgrounds to make things stand out. We should not include much content in the plot. Title, names for axis, scale, and legends are just enough.

Essential Skills for Data Visualization:

You should have the following data visualization skills for effective data visualization.

1. Programming

You should know R or Python language. R wins, hands down, when it comes to data visualization. Its ggplot2 library provides high-level functions to make complex plots with less code. Data visualization in Python can be done using libraries like matplotlib, plotly, bokeh and seaborn for data visualization. Plotly and bokeh can be used for interactive data visualizations.

2. Software Expertise

In addition to using R or Python languages, you can also use data visualization software such as Matlab, Minitab and SPSS for data visualization. Data visualization in Excel is also popular. However, they provide limited customizations for your plots. In addition to that, you cannot automate the plot creation process as you can do it with Python or R.

3. Data Science Skills

Data visualization is one of the data science skills. But, for effective data visualization, you need other data science skills such as statistical analysis, data cleaning, processing large data sets, data mining, etc. Data visualization cannot be done alone. It is a collection of these skills.

4. Public Speaking and Presentation

When it comes to presenting your findings to the company or other related people, you need to have excellent presentation skills. You should have more confidence when explaining things to a larger audience. For that, you should be familiar with the given problem domain.

5. Machine Learning

Machine learning is the ability of computers to learn from data without being explicitly programmed. It is completely different from traditional programming. We can use machine learning algorithms to find important patterns and features in the data. Then, we can visualize those things. There are machine learning algorithms that can be used to perform data cleaning before data visualization. Machine learning is part of the data visualization process.

Conclusion: Data visualization is important in every aspect of data science. We should clean our data before making any visualization. We should choose the right tool or software that addresses our needs, such as affordability, ease of use, etc. The main challenge in data visualization is choosing the right plot type. It depends on many factors. Finally, you need excellent public speaking and presentation skills to present your findings.

The goal of data science is to extract valuable information from data and use it to make data-driven decisions. Data scientists use various tools and techniques such as machine learning, data mining, and data visualization to identify patterns, trends, and insights from large datasets.

Data science is used in various industries such as healthcare, finance, marketing, and entertainment to improve business operations and decision-making processes. Some examples of data science applications

include fraud detection, customer segmentation, recommendation systems, and predictive analytics.

References

Here are some references for further reading on data visualization in data science:

1. "Data Visualization Best Practices Guide" by Tableau: <https://www.tableau.com/learn/whitepapers/datavisualization-best-practices-guide>
2. "The Power of Data Visualization" by Harvard Business Review: <https://hbr.org/2016/06/the-power-of-data-visualization>
3. "Data Visualization: A Practical Guide for Beginners" by Dataquest: <https://www.dataquest.io/blog/data-visualizationbeginners-guide/>
4. "Data Visualization Techniques: From Basics to Big Data with SAS Visual Analytics" by SAS: https://www.sas.com/en_us/whitepapers/data-visualization-techniques-108968.html
5. "Storytelling with Data" by Cole Nussbaumer Knaflic: <https://www.storytellingwithdata.com/>

These resources cover a range of topics related to data visualization in data science, including best practices, techniques, and tools. They can be helpful for anyone looking to improve their data visualization skills or to gain a deeper understanding of the importance of data visualization in data science



BLOCKCHAIN BASED E-VOTING SYSTEM

**Prashant Govardhan, Payal Chandel, Anand Kankirad,
Nirmiti Meshram, Shlok Mishra, Natasha Wanjari**

Computer Science and Engineering Department, Priyadarshini College of Engineering,
Hingna Rd, Digdoh Hills, Nagpur-440019, Maharashtra, India.

E-mail:-er.phgovardhan@gmail.com | Payallchandel@gmail.com
anandkankirad1@gmail.com | mishrashlok03@gmail.com
nirmitimeshram@gmail.com | natashawanjari11@gmail.com

Abstract

Highly advanced security methods are very necessary for introducing the effective online voting system in the whole world. An electronic voting has emerged as an alternative to paper-based voting to reduce redundancy and inconsistencies over time. The main aspect of security and transparency is a threat from global election with the conventional system. The General elections are still using a centralized system where one organization that manages it. Some of the problems that can occur in traditional electoral systems are with an organization that has full control over the database and system, it is possible to manipulate with the database. This paper presents a survey on some previous voting system that is used by different countries and organizations. Blockchain could be a unique technology of current era and blockchain guarantees to enhance the resilience of e-voting systems. this technique presents a shot to leverage edges of blockchain like cryptological foundations and transparency to attain an efficient theme for e-voting. The projected theme conforms to the elemental necessities for e-voting schemes and achieves end-to-end verifiability. The system presents in-depth analysis of the theme that with success demonstrates its effectiveness to attain Associate in Nursing end-to-end verifiable e-voting theme.

Keywords -

Ethereum, Voting, Decentralized, Blockchain, Nodes.

I. INTRODUCTION

Nowadays the elections are the very important protocols which helps the people to grow. In past, During the Process of counting the votes it has been done manually and it was very time-consuming process so we came up with the voter machine so that it will be easy to count the number of votes without consuming time. But there is one disadvantage of using this machine that is during this process anybody can do frauds and can misuse the data of candidates. so to avoid this misuse and frauds we came up with the blockchain technology. Blockchain technology is the security which will provide security to the system and it is one of the emerging technologies with strong cryptographic foundations which is used to resemble a data structure that maintains and shares all the transactions being executed

through its genesis. The voting system that uses electronic devices to take care of casting and counting votes is termed as e-voting system. The paper based on voting system is replaced by the e-voting. Now a days to decrease the load of man power and delay in result declaration of voting result e-voting system is more in demand by private or public organizations. It also saves papers which are made up of trees which will eventually save the natural disasters. E-voting nowadays has become a very practical way of voting. Electronic voting has many advantages over the traditional way of voting. Some of these advantages are lesser cost, faster tabulation of results, greater accuracy and lower the risk of human and mechanical errors.

II. BACKGOUND AND LITERATURE REVIEW

Literature survey is one of the most important steps in any of kind of research. Before start developing the system, we need to study the previous papers of our domain which we are working and on the basis of study we can predict or generate the drawback and start working with the reference of previous papers.

Paper title '**E-VOTING SYSTEMS USING BLOCKCHAIN: A SYSTEMATIC REVIEW AND FUTURE RESEARCH DIRECTION** [1] The Blockchain is a new kind of technology, it is a collection of multiple blocks that is, connected by nodes which is called as interconnected nodes that have their copy of the distributed records that contains the history of all transactions. Data is processed and stored in the blocks with the help of data mining process. Every block in blockchain contains a ledger of the previous block and hence it forms a chain of blocks, with the first block known as the genesis block. Hence, it forms a linked list type of Structure. Blockchain has a number of ledgers where data can only be appended but not deleted or tampered. It is immutable. Blockchain has two access specifier it can be public or private, in public mode anyone can modify the information into the blockchain and in private mode only those people can edit the information whose are authorised.

Paper title **VOTEETH: AN E-VOTING SYSTEM USING BLOCKCHAIN** [2] They proposed an e-Voting

system that utilized the blockchain. The system is decentralized and does not rely on trust. Any registered voter will have the ability to vote using any device connected to the Internet. The system is completely transparent for the voter use and the blockchain stores the logarithms of each of the transactions in a very secure manner which provides the assurance to the voter that his vote has been successfully casted and he may verify the same later at any point of time.

Paper title Blockchain Enabled E-Voting System [3] IN this paper they are try to proposed system involves a client server architecture integrated with a block chain system. The minimum requirements needed by a voter is a smartphone or a computer. The objectives of the adoption of the Blockchain technology in the solution are - To provide a support voting scheme that is open, fair and independently verifiable; To optimize the electoral process that enables secure, quick, cost effective, transparency and improved identity verification.

Paper title E-voting using block chain Technology [4] E-voting currently widely used by some countries in the world, for example in Estonia. The country has been using the e-voting system since 2005 and in 2007 conducted online voting and was the first country in the world to conduct online voting. Block chain itself has been used in the Bitcoin system known as the decentralized Bank system. By adopting block chain in the distribution of databases on e-voting systems one can reduce the cheating sources of database manipulation.

III. RELATED WORK

In this section, we briefly review the related work on Online Voting System, First, SQL is used which contains the verification data which is already stored. Second, the username and password are used to check whether the particular person is login or not. Instead of this, we can also use Aadhaar card provided the official information of the voter. Online is more efficient instead of offline mode and storing the voting data to secured online server. Results can be displayed by admin after entering user id and password. The proposed method is to build a Smart voting system using Blockchain for any voter in INDIA to cast the vote to their respective constituency from anywhere in INDIA by going to their nearest voting booth in the place of stay. Also, to develop a secure smart voting system which Provides the voter to vote from any region with in India to their Residential area and it is also very effective for a person who is not having a normal mobile phone with him/her and for those to access vote from the nearest Voting Booth with a secure voting process without neglecting to vote. This system provides security from all type of attacks, when vote is travelling from voting client to voting server from their experimentation because of the blockchain

encryption method.

These attacks include security threats from passive as well as active intruder. For authentication of voter instead of USERNAME, if we can use thumb impression or the OTP verification of voter or capture photo of his/her face and compare it with photo stored in our database, it will become more secure. Below given is the flow diagram of the proposed method

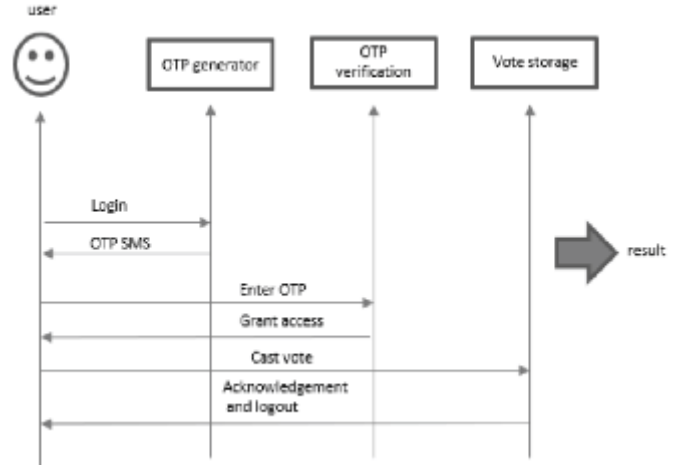

In This paper has shown the possibility of establishing E-Voting protocol based on public-key encryption. The security of the proposed E-Voting depends on RSA public key encryption protocol using blockchain. It allows the voter to vote from his/her own personal computer (PC) without any extra cost and effort. This protocol is proposed to replace the unreliable previous voting system, since voters feel justifiably confident that their votes will be counted and no one will be able to access it without them.

Below is the flow chart given: -



In this paper, a block-chain-based voting system. It needs time to popularize block-chain for a voting system as it is a novel idea and voting itself is a crucial matter in a

democratic country.

IV. METHODOLOGY

In The process the admin login into the system by importing the account. The accounts can be imported either using a security Key and Password or using a file. Both of these store reference to the account and details related to it. The admin can add a Candidate by function defined in the smart contract, Candidate Addition. sol. On Clicking, a dialog box pops up which takes in the details of the candidate, i.e., Name and Party or Side they represent. By calling this function, one instance of Article structure is created that stores the input as its variables.

This data is stored using database , That feeds the data provided in UI to the variables. It creates an artifact of the smart contract and using that artifact, it deploys the smart contract and stores it as an instance of the smart contract. Note: A new instance is created for each candidate added. This Add Candidate function is a Contract Call Transaction into the Blockchain. It deals with just a view type function, which doesn't bring any change in the state of Blockchain in terms of cost, except for the mining cost that the admin bears to the miner who mined for validation for the Block to be added to the Blockchain. This data is fed into the system using a smart-contract, after the admin signs the transaction of addition of candidate. This smart contract creates an instance of the smart contract as a Candidate object that stores all the data fed about the Candidate.

The libraries for this purpose and the code are written is JavaScript. The end result is a pie chart which using suitable info-graphic techniques. Ganache. If the account is newly created, 100 ethers are given to the account for the transaction. If it is imported, the details of the accounts are displayed on the UI. And that will also display the number of ethers in his account which can ensure whether he has the required amount or not. The UI is designed using HTML, CSS and JavaScript. The details are fetched from the blockchain and set to the front-end using jQuery.

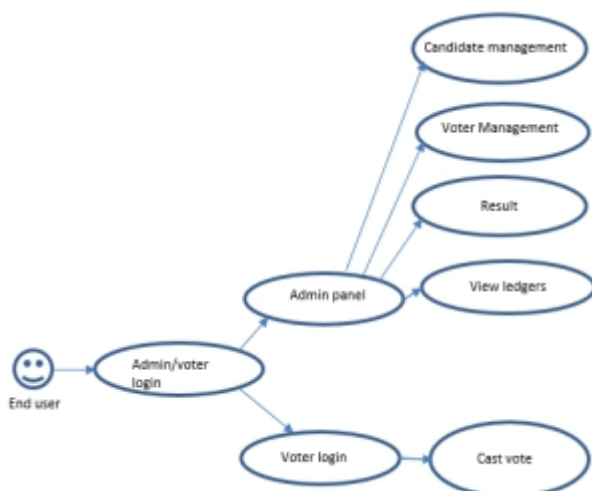

A voter at first logs into the system. He can achieve this by either creating a new account or importing a new one from the system. On casting the vote, he signs the transaction with its digital signature or by verifying it by the id password also. On signing the transaction, the transaction is published to the network and is mined by the Boot prefers. Generally, the vote is public, thus the information of vote is not encrypted but due to the security purpose we are keeping it encrypted.

The blockchain-based e-voting system can be applied to a variety of voting situations and other applications. In this paper, we have presented a proof-of-concept system for developing an e-voting system that utilized the Ethereum blockchain. The system is decentralized and does not rely on trust. Any registered voter will have the ability to vote using any device connected to the Internet but they can vote only once after that the system will be blocked. The Blockchain will be publicly verifiable and distributed in a way that no one will be able to corrupt it and in future work, we will be investigating the possibility of developing an in-house consensus algorithm to suit for the varying needs of security.

IV. DISCUSSION

In this voting system, the voter can cast their vote to only one leader for each post. If the voter can try to give their vote again then it would be restricted by the voting system and the message will be display on the voter side window, it can be updated in future extension of this project. The structural design has not included in prototype model of voting system.

We are implementing it for providing more security and transparency. It help to elected the best candidate for the development of area without doing any malpractice. The structural design of voting system can be upgraded in future by providing the IP addresses for more lucidity. This voting system will decrease the probability of forgery. The system can be easy to understand for the common people and cost efficient. The system has the ability to exchange and make use of information and has the potential to make the voting process easier and more efficient for the voters.

The targeted advantages of voting system are mentioned below.

- Time efficient
- Environment friendly.
- Accessible from anywhere.

V. CONCLUSION

This system is also used for corporate companies to conduct their elections for different posts such as the presidential election, manager election etc. The benefits of

choosing e-voting solution should outweigh the drawbacks, not only when compared to other electronic voting systems but also when compared to paper voting. Any additional cost incurred by e-voting should be justified by the benefits that can be expected from the solution. Propose a blockchain-based e-voting scheme, which meets the essential requirements of e-voting process. All votes in the blockchain are cryptographically linked block by block. The block with a higher value of signature is selected over others when the others when they have the same timestamp.

VI. REFFERNCE

- [1] E-VOTING SYSTEMS USING BLOCKCHAIN: A SYSTEMATIC REVIEW AND FUTURE RESEARCH DIRECTION Dhiraj Amrutkar*, Gaurav Dongare*, Sayog Sonune*, Archana Y. Chaudhari**
- [2] See discussions, stats, and author profiles for this publication at <https://www.researchgate.net/publication/353731219> VOTEETH: AN E-VOTING SYSTEM USING BLOCKCHAIN Article · June 2019 DOI: 10.26562/IRJCS.2019.JNCS10081
- [3] Vol. 8, Issue 4, April 2019 Copyright to IJARCCCE DOI 10.17148/IJARCCCE.2019.8412 77 Blockchain Enabled E-Voting System Sri Raksha S Arun1, Shibani2, Spoorthi S3, Vaishnavi R Kamath4, Dr. C Vidya Raj5 Department of Computer Science and Engineering, The National Institute of Engineering Mananthavadi Road, Mysuru, India1,2,3,4,
- [4] E-voting using block chain Technology Prof. Pallavi Shejwal1, Aditya Gaikwad2, Mayur Jadhav3, Nikhil Nanaware4, Noor Mohammed Shikalgar51 Assistant Professor, 2,3,4,5 BE Students, Department of Information Technology, BSIOTR, Pune, Maharashtra, India
- [5] Blockchain technology-based e-voting system. Prof. Anita A. Lahane1, Junaid Patel1, Talif Pathan1, and Saranya, R. Mahalakshmi, J. Ram Prabu, "Smart Electronic Voting Machine surveillance", International Journal of Engineering and Advanced Technology (IJEAT) ISSN: 2249 8958, Volume-8, Issue- 2S, December 2018. 6.
- [6] Prathmesh Potdar1, ITM Web of Conferences 32, 03001 (2020) ICACC-2020
- [7] Private, public, and consortium blockchains - what's the difference? <https://www.binance.vision/blockchain/private-public-and-consortium-blockchains-what's-the-difference>. Accessed: 2020-01-24
- [8] Ashish Singh, Akali Chatterjee, Sec EVS: Secure Electronic Voting System Using Blockchain Technology, International Conference on Computing, Power and Communication Technologies (GUCON) Galotti's University, Greater Noida, UP, India. Sep 28-29, 2018.
- [9] Private, public, and consortium blockchains - what's the difference? <https://www.binance.vision/blockchain/private-public-and-consortium-blockchains-what's-the-difference>. Accessed: 2020-01-24 What is blockchain. <https://www.investopedia.com/terms/b/blockchain.asp>. Accessed: 2020-01-24.

OBJECT DETECTION ON CONSTRUCTION SITE

Rupali Saha, Snehal Motghare, Aachal Mate, Tanushri Sapate, Kirti Gokhale, Sakshi Channe

Computer Science and Engineering Department,

Priyadarshini College of Engineering, Hingna Rd, Digdoh Hills, Nagpur-440019, Maharashtra, India.

E-mail:

snehalmotghare69@gmail.com | aachalmate143@gmail.com

sapatetanu@gmail.com | kirtigokhale@gmail.com | sakshichanne31@gmail.com

Abstract

The Detection is one of the wonderful inventions of Human-Computer Interaction (HCI) technology. It is necessary for workers to wear helmets, Coat, Shoes when working in large construction sites. The object detection technology has gradually become an active research topic, and used in many aspects of our daily life, and people are also exploring more directions that can be applied to object detection. The object detection mainly obtains the original image through the camera, and detects the object through the analysis of the original image, based on the target features. It is necessary for workers to wear helmets when working in large construction sites. The traditional way to supervise the workers whether wearing helmets or not for safety is artificial.

In the methods, the report focuses on the framework design and the working principle of the models and analyzes the model performance in the real time and the accuracy of detection. With the recent advancement in machine neural network in image processing, classifying and detecting the object accurately is now possible. In this report Convolutional Neural Network (CNN) is used to detect object in the environment According to the abundant research on object detection, many traditional object detection methods have been proposed. With the development of advanced technologies, automation in construction has improved substantially. Safety monitoring, an important task in construction, is usually undertaken and recorded manually. We also introduce some typical data set use for the testing or training the object detection model. This record made a systematic classification and summary in object detection field, which can be meaning full and use full for the study about the object detection.

Keywords :

Machine learning, neural network, Construction Image classification, Object Detection; R-CNN , Faster RCNN,, YOLOv7, Tensorflow .

I. INTRODUCTION

The Detection is one of the wonderful inventions of Human-Computer Interaction (HCI) technology. It is necessary for workers to wear Person, helmets, Coat,

Shoes when working in large construction sites. The object detection technology has gradually become an active research topic, and used in many aspects of our daily life, and people are also exploring more directions that can be applied to object detection. The object detection mainly obtains the original image through the camera, and detects the object through the analysis of the original image, based on the target features.[1]

The object detection technology has gradually become an active research topic, and used in many aspects of our daily life, and people are also exploring more directions that can be applied to object detection. The object detection mainly obtains the original image through the camera, and detects the object through the analysis of the original image, based on the target features. It is necessary for workers to wear helmets when working in large construction sites. The traditional way to supervise the workers whether wearing helmets or not for safety is artificial.[3]

The object detection based on machine learning is an important technology. The difficulties in small objects detection are their low resolution and little semantic information. Compared with the traditional detection algorithms, machine learning can usually obtain higher detection accuracy, more accurate Bounding Box borders, and lower missed and false detection rate. Some networks are applicable to object detection or helmet detection in relatively close shot with fairly satisfactory results so far. But few networks can detect helmet at the same time. We improve the Faster R-CNN to detect object and helmets simultaneously with small size in low-resolution.[3] The person detection are classified into close shot and whole scene detection. Close shot detection is easy to implement, and many existing detection networks can solve it. And their helmets are even smaller. The difficulties in small objects detection are their low resolution and little semantic information. The detection networks are mainly two categories such as R-CNN , Fast R-CNN , Faster R-CNN , and a one-stage single object detection, such as SSD. With the development of advanced technologies, automation in construction

has improved substantially. This leads to an increasing number of different new technologies adopted in the construction industry to benefit from their introduction. Safety monitoring, an important task in construction, is usually undertaken and recorded manually. Monitoring construction progress accurately can help contractors control and manage costs and scheduling. This report also indicated that construction organizations are adopting AI to extract information from large masses of data to improve construction safety and progress efficiency.[4]

II. BACKGROUND & LITERATURE REVIEW

The purpose of this project is to develop a to improve the efficiency and accuracy of monitoring safety and modular installation progress on construction sites, the modular objects should be detected .This leads to an increasing number of different new technologies adopted in the construction industry to benefit from their introduction. Safety monitoring, an important task in construction, is usually undertaken and recorded manually. Monitoring construction progress accurately can help contractors control and manage costs and scheduling.

First, image data were taken from different construction sites. In the second step, object detection models were built in the TensorFlow platform. Configuring the computer development environment, deep learning platform (TensorFlow) and object detection API were the three main tasks in this step. Third, the models based on chosen object detection algorithms were trained on the training data set and adjusted based on validation data sets to improve the generalizability of the object detection algorithm to unseen data. Two models based on faster RCNN and SSD were trained on the labelled images. The number of images, the chosen algorithm and training steps influenced detection accuracy. The last step was to analyze the performance- trained models across the selected metrics.[1]

The Following describes the overall objective of this project:

- To program the camera to capture the images, which will be used to analyze the table number will be analyzed by using image processing techniques. As stated above, the capture images in the real time, the images will undergo a series of process with the help of R-CNNs algorithm.
- To improve the efficiency and accuracy of monitoring safety and modular installation progress on construction sites, the modular objects should be detected and tracked.

- Faster RCNN and SSD are selected for training models in TensorFlow. Trained object detection models were evaluated across the following metrics with test data sets .

III. RELATED WORK

A. Incorporate Technologies

The main components used to design the software are described below:

1 R-CNN

Object detection is the process of finding and classifying objects in an image. One deep learning approach, regions with convolutional neural networks combines rectangular region proposals with convolutional neural network features. R-CNN is a two-stage detection algorithm. The first stage identifies a subset of regions in an image that might contain an object. The second stage classifies the object in each region. The R-CNN detector first generates region proposals using an algorithm such as Edge Boxes. The proposal regions are cropped out of the image and resized. Then, the CNN classifies the cropped and resized regions. Finally, the region proposal bounding boxes are refined by a support vector machine (SVM) that is trained using CNN features.

Models for object detection using regions with CNNs are based on the following three processes:

- Find regions in the image that might contain an object. These regions are called region proposals.
- Extract CNN features from the region proposals.
- Classify the objects using the extracted features. These networks usually consist of—
 - a) A region proposal algorithm to generate “bounding boxes” or locations of possible objects in the image;
 - b) A feature generation stage to obtain features of these objects, usually using a CNN;
 - c) A classification layer to predict which class this object belongs to; and
 - d) A regression layer to make the coordinates of the object bounding box more precise.

2 Faster R-CNN

Faster R-CNN is an object detection model that improves on Fast R-CNN by utilizing a region proposal network (RPN) with the CNN model. The RPN shares full- image convolutional features with the detection network, enabling nearly cost-free region proposals. It is a fully convolutional network that simultaneously predicts object bounds and abjectness scores at

each position. The RPN is trained end-to-end to generate high-quality region proposals, which are used by Fast R-CNN for detection. RPN and Fast R-CNN are merged into a single network by sharing their convolutional features: the RPN component tells the unified network where to look. As a whole, Faster R-CNN consists of two modules.

The first module is a deep fully convolutional network that proposes regions, and the second module is the Fast R-CNN detector that uses the proposed regions.

3 TensorFlow

TensorFlow are open-source libraries for numerical computation and large-scale machine learning that ease Google Brain TensorFlow, the process of acquiring data, training models, serving predictions, and refining future results. The TensorFlow Object Detection API is an open-source framework built on top of TensorFlow that makes it easy to construct, train and deploy object detection models.

- TensorFlow bundles together Machine Learning and Deep Learning models and algorithms.
- It uses Python as a convenient front-end and runs it efficiently in optimized C++.
- TensorFlow allows developers to create a graph of computations to perform.
- Each node in the graph represents a mathematical operation and each connection represents data. Hence, instead of dealing with low-details like figuring out proper ways to hitch the output of one function to the input of another, the developer can focus on the overall logic of the application.

4 Yolov7

YOLOv7 surpasses all known object detectors in both speed and accuracy in the range from 5 FPS to 160 FPS and has the highest accuracy 56.8% AP among all known real-time object detectors. Focusing on Object detection models, there are many different object detection models which perform well for certain use cases, but the recent release of YOLOv7, where the researcher claimed that it outperforms all known object detectors in both speed and accuracy and has the highest accuracy 56.8% AP among all known real-time object detectors. The proposed YOLOv7 version E6 performed better than

transformer-based detectors like SWINL Cascade-Mask R-CNNR-CNN in terms of speed and accuracy. YOLOv7 outperformed YOLOX, YOLOR, Scaled-YOLOv4, YOLOv5, DETR, Deformable DETR, DINO-5scale-R50, and Vit-Adapter-B. In further reading, we will see what made YOLOv7 outperform these models.

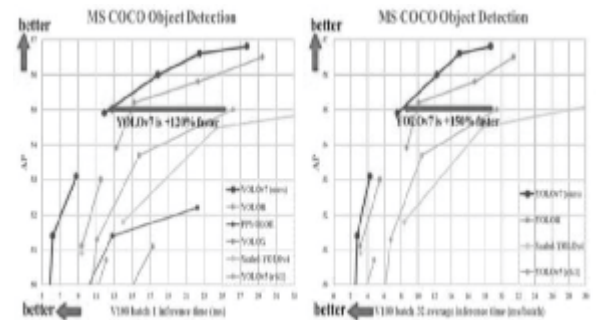

Fig 1. Training bag of freebies sets new states of the art for real time object detectors

4 PYQT

PyQt brings together the Qt C++ cross-platform application framework and the cross-platform interpreted language Python. Qt is more than a GUI toolkit. It includes abstractions of network sockets, threads, Unicode, regular expressions, SQL databases, SVG, OpenGL, XML, a fully functional web browser, a help system, a multimedia framework, as well as a rich collection of GUI widgets.

Qt classes employ a signal/slot mechanism for communicating between objects that is type safe but loosely coupled making it easy to create re-usable software components. Qt also includes Qt Designer, a graphical user interface designer. PyQt is able to generate Python code from Qt Designer. It is also possible to add new GUI controls written in Python to Qt Designer.

5 RestAPI

Representational State Transfer (REST) is an architectural style that defines a set of constraints to be used for creating web services. REST API is a way of accessing web services in a simple and flexible way without having any processing. REST technology is generally preferred to the more robust Simple Object Access Protocol (SOAP) technology because REST uses less bandwidth, simple and flexible making it more suitable for internet usage. It's used to fetch or give some information from a web service. All communication done via REST API uses only HTTP request.

Working: A request is sent from client to server in the form of a web URL as HTTP GET or POST or PUT or DELETE request. After that, a response comes back

from the server in the form of a resource which can be anything like HTML, XML, Image, or JSON. But now JSON is the most popular format being used in Web Services.



Fig.2 RestAPI

B. Methodology

System hardware was used to test the algorithm's real-time processing with field data. It consisted of Intel Core i7- 790@3.60GHz 8 CPU and Intel HD Graphics GPU with 8GB 1600MHz RAM. Ubuntu 16.0 base environment consists of python3, pip, OpenCV and Tensorflow. Image annotation is performed on the label using Image-master software, an open source software available on GitHub. The development was done with jupyter notebook and atomic text editor was used. The YOLOv7 model is used to convey learning in the spherical framework. The YOLOv7 trained weights are used as the initial set of CNN weights, and the convolutional and fully connected layers are opened for training using construction data. This is true for both Yolov7 and Faster RCNN models .

In the project firstly we have the environment setup then the algorithm are used i.e. YOLO (network modification for transfer learning) and TensorFlow. These are the library's of python and use for object detection. The yolo is one type of machine learning in which the images are read in the form of matrix i.e. pixels in the form of (0,1). It is also called as annotation. The roboflow data set is use to detect the objects in the dataset many images are gather and than the images go to many phases that are training ,preparation, validation.

Roboflow is a computer vision platform that enables users to build computer vision models faster and more accurately by providing better data collection, pre-processing and model training techniques. Roboflow allows users to load custom datasets, draw annotations, edit image orientations, resize images, change image contrast, and perform data augmentations. It can also be used to train models. As I mentioned, Roboflow also has a generic conversion tool that allows users to load and convert annotations from one format to another without having to write conversion scripts for custom object detection

datasets. First we need to login at <https://roboflow.com/>. Note that if you select the "PublicWorkspace" option when you sign up for a free tier account, you can upload image sets of up to 10,000 source images. After creating a project, the next step is to load a dataset containing both images and existing annotation files (can be in JSON, Txt or XML format) or design annotations from scratch. The last step after preparing the dataset is to export the data in ZIP format.

The data gather from the many construction sources. Then the images go to dataset for the image detection (helmets, no helmets, jacket , no jacket).The models presents in database are trained then the output is show.

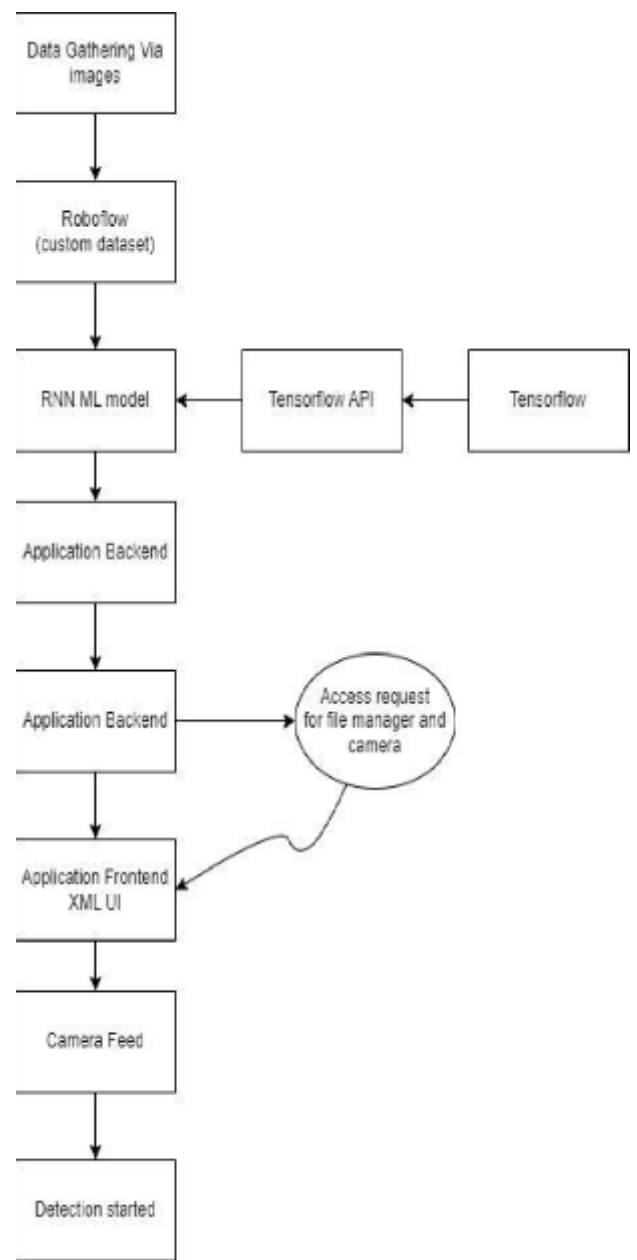

Fig. 3. Flow Diagram for Proposed System Work

Data preparation

Selected modular objects included safety barricades, fences and panels. These three types of construction objects were easier to access than other objects, such as steel structure and prefabricated composite walls, and were commonly found at construction sites. Considering the limitation of time and construction sites, only one shape of each kind of object was selected for this object detection research. After pre-processing, the image data were divided into training, validation and test sets. This research selected faster RCNN and SSD for object detection. They are two of the most common algorithms in computer vision. In this study, 990 images covering three types of objects were chosen for all training, validation and testing samples.[2]

Model training

The number of images for each object detection was also guided by earlier investigators examining object detection and was limited to 1000 applied and images for training, validation and test data sets to a people-oriented detection test, and also applied 100, 50 and 50 images to a different people-oriented detection test. 150 images for each detected object, such as cell phones. In addition, the number of panels was lower than the number of barricades and fences. The reason was that panel images of the target type were harder to find and collect than those of the other two because only the Dee Why construction site used that type of panels. Hence, there were fewer images in panel data sets than fence and barricade sets.[2]

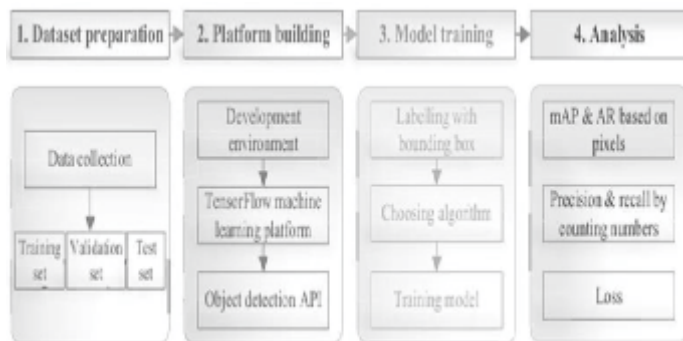

Fig 5. Working Module

Platform and model building

This study is implemented based on TensorFlow platform, which contains several deep learning algorithm packages for convenience of programmers. Faster RCNN and SSD models are trained and validated after the installation of TensorFlow. Microsoft Common Objects in Context (COCO) pre-trained faster RCNN and SSD models were chosen instead of the training-from-scratch approach. A pre-trained model was applied to save training time and compensate for not having a big data set. The use of the COCO data set resulted in a straightforward fine-tuning of the parameters for the training set.[2]



Fig. 6. Component Detection

I. DISCUSSION

In this Comprehensive study on two algorithms namely : Faster RCNN , and YOLOv7 we Compared their Inference Speeds , Performance and map accuracies .Even though the accuracy of YOLOv7 is higher in comparison to the accuracy of Faster RCNN model .

Object detection are a new technology .This leads to an increasing number of different new technologies adopted in the construction industry to benefit from their introduction. Safety monitoring, an important task in construction, is usually undertaken and recorded manually.

- 1) Object detection is a computer vision technique that allows us to identify and locate objects in an image or video.
- 2) With this kind of identification and localization, object detection can be used to count objects in a scene and determine and track their precise locations, all while accurately labeling them.
- 3) The future of object detection technology is in the process of proving itself, and much like the original Industrial Revolution, it has the potential to free people from menial jobs that can be done more efficiently and effectively by machines.
- 4) Improve construction safety and progress efficiency.

II. CONCLUSION

This study used machine learning-based computer vision algorithms in the automated detection of the key processes that sustain construction safety and on-site management. Using YOLOv7 and Faster RCNN , a

state of art object detection algorithm, this study demonstrates how safety compliance can be automatically detected by using a trained model to examine data from sites. The study demonstrated the deployment of such algorithms on construction sites to aid near real-time detection of safety violations.

The study also used supervised machine learning techniques, and future research would benefit from a combination of supervised and unsupervised techniques to generate more intelligent systems. The development of this business intelligence is an ongoing effort. The present models form one piece of larger frameworks, which could be evolved to completely automate safety monitoring without manual interventions. Such frameworks might use sensing technologies beyond vision to create an ability to understand the safety conditions in a more comprehensive manner. Future applications and technologies might make use of techniques such as the Internet of Things (IoT) and other big data to completely automate responses to hazards. These research directions present exciting opportunities for enhancing safety in the construction industry. This study has presented a cutting edge deep learning-based computer vision algorithm with substantial implications and applications that opens up possibilities for incorporating machine intelligence that can automatically predict and monitor safety.

The number of images used in this experimentation was limited to 700 due to the accessibility of construction sites. While the number of images used for similar image processing experiments in construction is limited to 500 in the literature, some scholars in other disciplines have used over 1,000 images for detection purposes. Hence, the number can be increased in the future if the situation allows the researcher to collect the data.

In the future, risk ratings for projects can be potentially computed based on object detection. Moreover, the application of object detection can be used for generating data related to a project, and then elements of real-time training can be implemented to enhance skills and improve team leadership. In this report, we proposed a framework to improve construction safety management. In the framework, the visual relationship detection methods based on deep learning are used to detect multiple interactions between objects in images.

detection[J]. IEEE Transactions on Circuits and Systems for Video Technology, 2005, 15(10): 1210-1224.

- [2] Zhao Z Q, Zheng P, Xu S, et al. Object detection with deep learning: A review[J]. IEEE transactions on neural networks and learning systems, 2019, 30(11): 3212- 3232. Agarwal, A., Gupta, P., Iqbal, F., Kumar, A., & Madani, A. (2014). Robot as a Waiter For Restaurants. International Journal of Scientific Research and Management Studies (IJSRMS), 3(7), 271-274.
- [3] Ahmadi-Karvigh, S., Becerik-Gerber, B. and Soibelman, L. (2019), "Intelligent adaptive automation: a framework for an activity-driven and user-centered building automation", Energy and Buildings, Vol. 188-189, pp. 184-199, doi: 10.1016/j.enbuild.2019.02.007.
- [4] Alsing, O. (2018), Mobile Object Detection Using TensorFlow Lite and Transfer Learning, DiVA. Blanco, J.L., Fuchs, S., Matt, P. and Ribeirinho, M.J. (2018), "Artificial intelligence: construction technology's next frontier", Building Economist, pp. 7-13P. F. Felzenszwalb et al., "Object detection with discriminatively
- [5] [2] K.-K. Sung and T. Poggio, "Example-based learning for view-based human face detection," IEEE Trans. Pattern Anal. Mach. Intell., vol. 20, no. 1, pp. 39-51, Jan. 1998.

REFERENCE

- [1] Dasiopoulou S, Mezaris V, Kompatsiaris I, et al. Knowledge-assisted semantic video object

DESIGN AND ANALYSIS OF ROLL CAGE OF ELECTRIC CARGO VEHICLE

Manasi Gawali | Akshay Madane | Raghavendra Kerkar | Rohit Kale

Student-Mechanical Engineering Department Smt. Kashibai Navale College of Engineering
44/1, Vadgaon (Bk), Off Sinhgad Road, Pune - 411041.

Email :

manasigawali2001@gmail.com | akshaymadane64@gmail.com |
raghavkerkar2000@gmail.com | rohitkale2579@gmail.com

Abstract

The objective is to reduce the wall thickness of the roll cage pipe while maintaining its strength and safety parameters, in order to achieve weight reduction and increased efficiency of the vehicle. We have used CATIA V5 to design the roll cage and ANSYS 2022 R1 & R2 for simulation due to its powerful meshing and post-processing capabilities, as well as its dynamic and intuitive graphical user interface. The optimization process involved testing various thicknesses of pipes and analysing the resulting deformation and stress distribution in the roll cage. Graphical representations were used to visualize the parameter relationships, and the suitable design was selected for fabrication and welding. Overall, it involves the design, analysis, selection, optimization, and graphical representation of the roll cage, with the aim of achieving a lightweight yet strong and safe design. The roll cage is one of the main subsystems of the electric car and is responsible for mounting other subsystems. Aim of our current research is to construct an optimized roll cage and identify the perfect material for the designed roll cage, with an objective to enhance the value of the factor of safety for the electric car. The analysis is carried out for a range of force values for all impact tests, considering reliability, strength of material, ease of manufacturing, driver ergonomics, energy absorption ability, and structural rigidity. The design procedure follows all the rules laid down by SAE Efficycle 2022 Rulebook for electric car.

Keywords :

Chassis, Roll cage, EV, Catia V5, Ansys Workbench 2022 R1 & R2, Static Analysis, Model Analysis, Dynamic Analysis, strength, material selection.

I. INTRODUCTION

A roll cage is the main skeleton of any ATV hence, acts as a support for the vehicle. Before starting the design, it is essential to take into account worst-case scenarios. The main function of a vehicle chassis is to support the vehicle's mechanical components and deal with static and dynamic loads, without undue deflection or distortion. Hence, it must also have high torsional stiffness. For use on any terrain, it should be constructed with ergonomics in mind and be sturdy

and effective while being as light as possible.

The roll cage is designed and manufactured according to the rulebook of Efficycle SAE INDIA 2022(Efficycle). To accurately analyse the build quality of the vehicle CAD model, it is meticulously tested. The main considerations in the process of roll cage design are driver's safety ergonomics and its robustness. It commenced with the study of rulebook specifications. In accordance the 3D CAD design was made in CATIA V5. Furthermore, meshing and analysis of frame for front, side, rear and roll over, torsional impact, etc. were performed in ANSYS Workbench 2022 R1 & R2. Issues faced while designing a reliable and efficient EV chassis are that, it should support heavy loads for commercial use, ensuring the safety and durability of the chassis under varying weather and road conditions, identifying and addressing any regulatory or compliance requirements related to the development and operation. Developing a cost-effective solution that is competitive with traditional commercial vehicles and meets the needs of businesses that rely on transportation for their operations. Overall, the goal is to create a cargo commercial EV vehicle chassis that is a viable alternative to traditional commercial vehicles that use fossil fuels, while also meeting the unique demands of the commercial transportation industry.

II. DESIGN OF ROLL CAGE

A. DESIGN METHODOLOGY

The design and development process of the roll cage is indeed a critical aspect that can significantly impact the safety and performance of the vehicle. Material selection, cross-sectional determination, frame design, and finite element analysis are all essential factors that need to be considered to ensure that the roll cage is reliable and safe. To choose the best material for the roll cage, thorough research was conducted, and various materials were compared based on strength, weight, cost, and availability in India. The primary objective was to identify the optimal material that meets all the necessary criteria for the roll cage design. [2]

B. MATERIAL SELECTION AND CROSS

The roll cage material selection for the vehicle competing in the SAE India Effi-cycle competition must follow the rules in the rule book provided by SAE India Efficycle[1]. The frame must be strong, protective, and ergonomic, serving as the foundation for other subsystems. It should protect the driver in collisions and prevent debris from entering while withstanding severe track conditions. Based on the criteria and requirements specified in the rule book, it appears that the selection of AISI4130 steel for the roll cage material is a suitable choice. The material has the necessary properties, including high ultimate tensile stress and yield stress, which are important for providing protection to the driver during collisions and breakdowns.

Furthermore, the presence of chromium and molybdenum in the AISI 4130 steel increases its strength and corrosion resistance, making it an ideal choice for the roll cage. Additionally, its good weldability and machinability make it easy to manufacture. The bending strength & bending stiffness of the cross section used in frame must be equal or more than bending strength & bending stiffness when a circular cross section of 1 inch (or 25.4mm) outer diameter and 0.078-inch (2 mm) wall thickness with carbon percentage 0.18%.

C. FRAME DESIGN

Following are some of the factors which are considered while designing the Roll Cage: [1]

Table 1: Design Values

CONSIDERATIONS	RECOMMENDED	ACHIEVED
Weight	28 to 35 Kg	32 Kg
Maximum vehicle width (inches)	1200 mm (47.244 inches)	990.599mm [38.9inches]
Maximum vehicle length (inches)	2200mm (86.614 inches).	1,772.92 mm [69.8inches]

The Chassis design was made according to the loops and it was assembled with various other system components modelled in CATIA software.

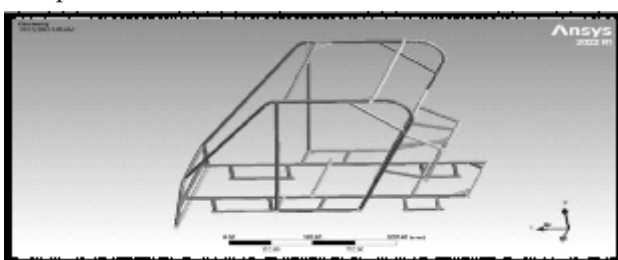

Fig. 1: Iteration-1

According to FEA results the first iteration made for chassis failed, so providing some triangulations and members we proceeded towards second iteration.

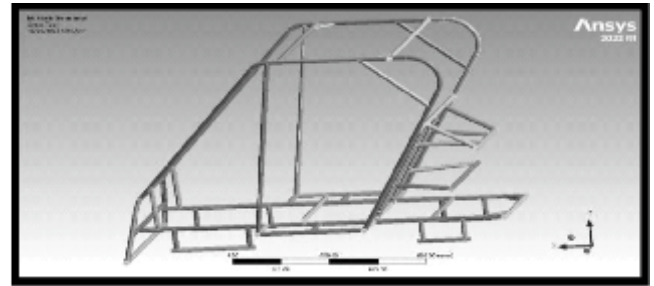

Fig. 2: Iteration-2

Second iteration of chassis successfully passed the FEA analysis; with these results the dummy chassis model was made. On making the dummy model we faced some mounting problems with this model.

D] Prototype/dummy chassis image



Fig. 3: Dummy Chassis

We faced a few issues with the mountings, therefore further changes were done and made sure that it satisfies the FEA conditions. This is how third iteration came into picture before finalizing the roll cage. [2]

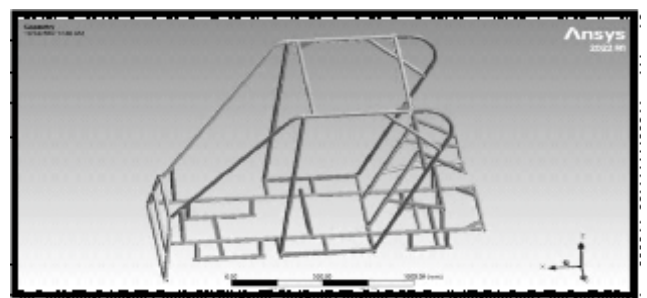

Fig. 4: Final Roll Cage Design

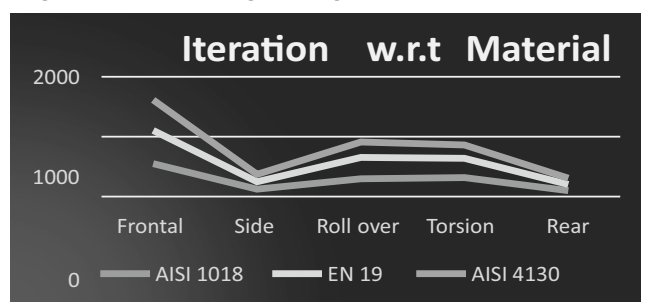

Fig. 5: Iteration stress results w.r.t. Material

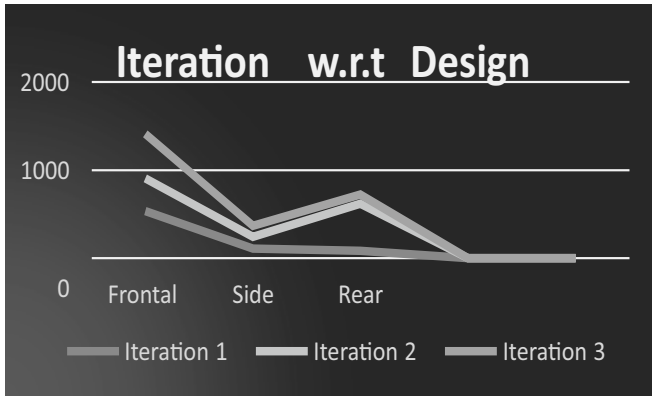

Fig. 6: Iteration stress results w.r.t. Design

III. ANALYSIS [3]

A. FRAME MATERIAL DETAILS

As per the rulebook constraints the material for roll cage should have 0.18% of carbon content. Accordingly, three options of materials are taken into account i.e., EN 19, AISI 1018 and AISI 4130.

- i. Material-1 (EN 19)
Cross-Section Type; A x B x t
; 25.4 mm*21.4*2
- ii. Material-2 (AISI 1018)
Cross-Section Type; A x B x t
; 25.4 mm*21.4*2
- iii. Material-3 (AISI 4130)
Cross-Section Type; A x B x t
; 25.4 mm*21.4*2

where;

A= Outer diameter for circular section = 25.4 mm

B= Inner diameter for circular section = 21.4 mm

t= wall thickness = 2 mm

TABLE 1:
CHEMICAL COMPOSITION COMPARISON

CHEMICALS	AISI 4130	EN 19	AISI 1018
Carbon	0.29	0.35	0.20
Phosphorous	0.035	0.035	0.04
Manganese	0.42	0.50	0.60
Sulphur	0.04	0.04	0.05
Silicon	0.27	0.15	0.10

TABLE 2: MECHANICAL PROPERTIES

PROPERTIES	AISI 4130	EN 19	AISI 1018
Yield Strength	460 MPa	415 MPa	370 MPa
Ultimate Strength	560 MPa	655 MPa	440 MPa
Modulus Of Elasticity	210 GPa	200 GPa	205 GPa
Density	7.85 g/cm ³	8.08 g/cm ³	7.87 g/cm ³
Poisson's Ratio	0.29	0.27	0.29

B. CALCULATION OF BENDING STRENGTH AND BENDING STIFFNESS [1]

FOR AISI 4130:

BENDING STRENGTH:

$$I1 = \pi * (R14 - R24) / 64I1 = 10136.74 \text{ mm}^4$$

$$M1 = Sy * I1 / C$$

$$M1 = 616.98425 \text{ Nm BENDING STIFFNESS: } K1 = EI1 \text{ (AISI 4130)}$$

$$K1 = 210 * 10^4 * 10136.74 \text{ N mm}^2$$

$$K1 = 2.1287 * 10^4 \text{ Nm}^2 \text{ FOR}$$

where,

I = Moment of Inertia R1 = Outer Diameter R2 = Inner Diameter M = Bending Moment

SY = Tensile Yield Strength C = Radius of Curvature

E = Young's Modulus

C. CAE ANALYSIS OF VEHICLE/FRAME Assumptions [6]

- The roll cage material is isotropic.
- All the roll cage material is having uniform cross-section.
- Roll cage is stationary, i.e., we are considering the situation when our roll cage is stationary and some other vehicle has impacted on our vehicle from front side.
- Time of impact
- Speed of ATV impacting on my roll cage
- Force location
- Constraint's location

1) Frontal Impact Analysis

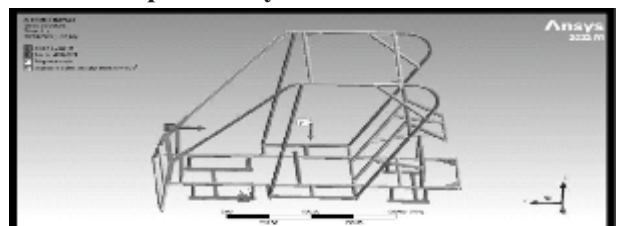

Fig. 7: Nodal Force for Front Impact

Calculation of Impact Forces:

Weight of the vehicle,
 $M = 200 \text{ kg}$ (Including one driver.)
 Velocity of vehicle = 12.90 m/s
 Final velocity = 0 m/s
 Impact time = 0.3 sec from work energy principle
 Work done = change in K.E $F = 4584.3 \text{ N}$

ANALYSIS RESULTS

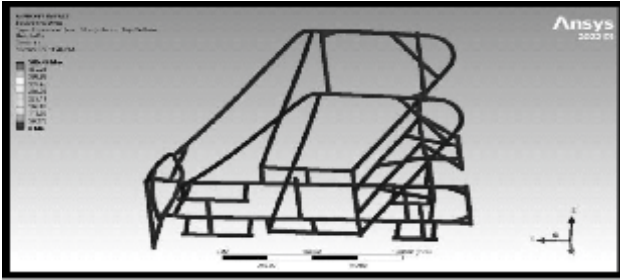

Fig. 8: Front Impact Stress

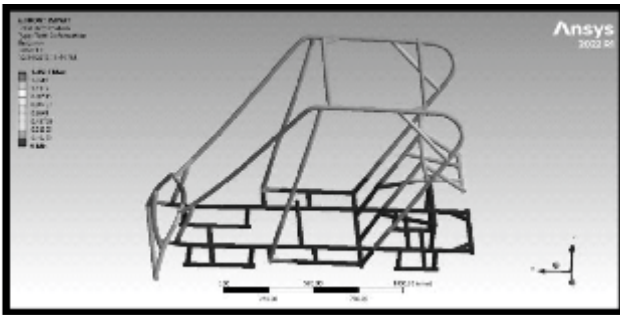

Fig. 9: Front Impact Deformation

2) Side Impact Analysis

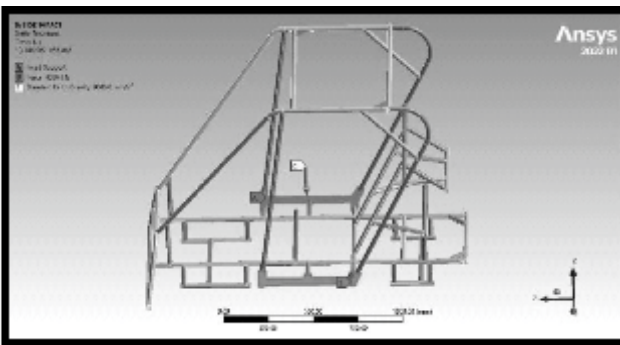

Fig. 10: Nodal force for Side Impact

- Calculation of Impact Forces:**
 Weight of the vehicle, $M = 200 \text{ kg}$
 (Including one driver)
 Velocity of vehicle = 12.90 m/s
 Final velocity = 0 m/s
 Impact time = 0.3 sec
 From work energy principal
 Work done = change in K.E
 $F = 4584.3 \text{ N}$

Analysis Results:

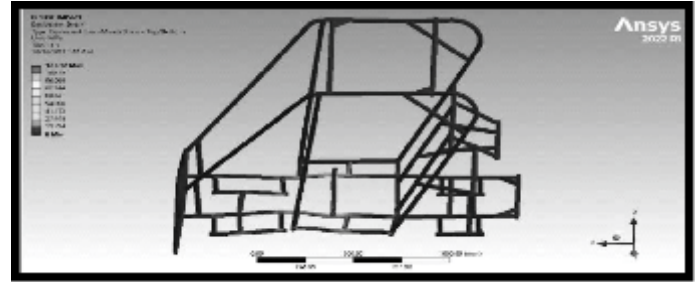

Fig. 11: Side Impact Stress

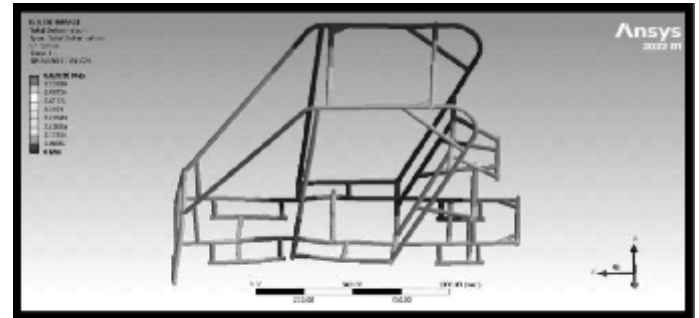

Fig. 12: Side Impact Deformation

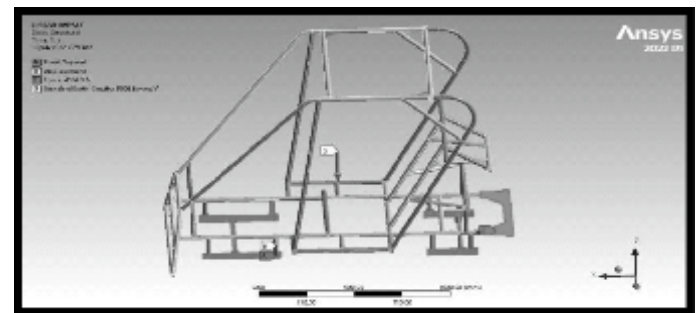

Fig. 13: Nodal Force for Rear impact

- Calculation of Impact Forces:**
 Weight of the vehicle,
 $M = 200 \text{ kg}$ (Including one driver.)
 Velocity of vehicle = 12.90 m/s
 Final velocity = 0 m/s
 Impact time = 0.3 sec From work energy principle
 Work done = change in K.E $F = 4584.3 \text{ N}$

Analysis Results:

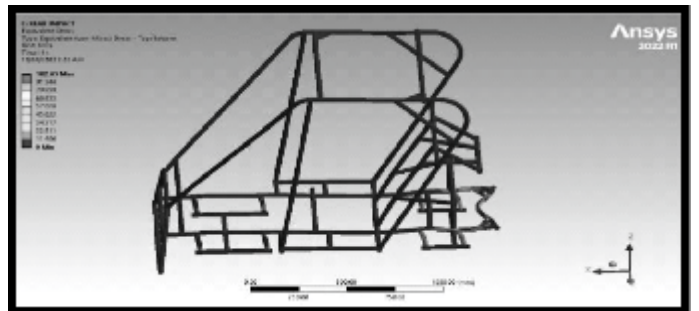

Fig. 14: Rear Impact Stress

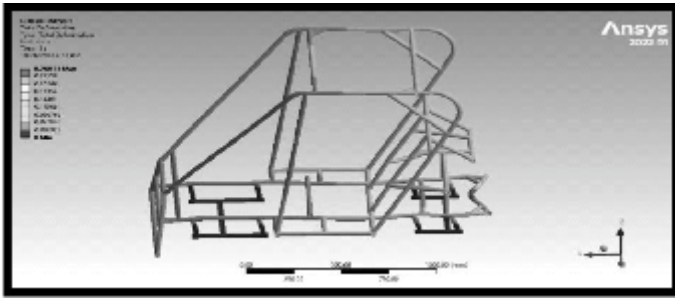

Fig. 15: Rear Impact Deformatio

4. Rollover Analysis

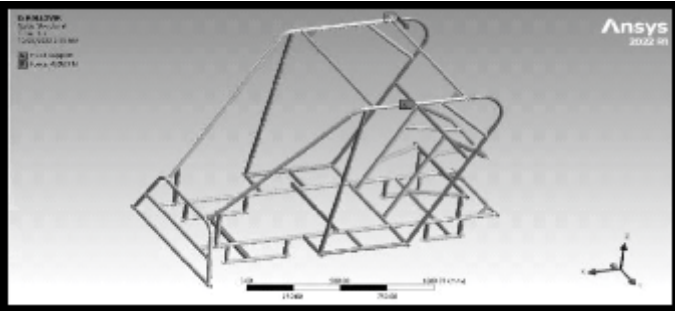

Fig.16: Nodal force for rollover

- **Calculation of Impact Forces :**
 Weight of the vehicle,
 $M = 200 \text{ kg}$ (Including one driver.)
 Impact time = 0.13sec height = 1.524m
 Potential energy = Kinetic Energy [11]
 $F = 4208.28 \text{ N}$.

- **Analysis Results :**

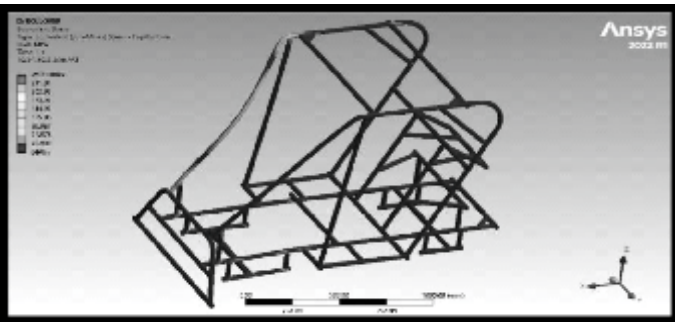

Fig.17: Rollover Stress

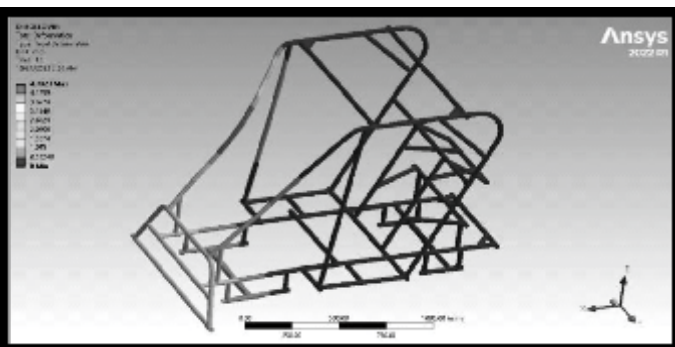

Fig.18: Rollover Deformation

3. Bending Analysis

Self-weight bending:

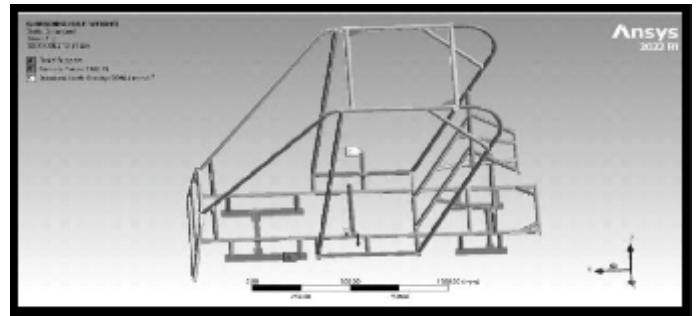

Fig.19: Nodal force for bending impact

- **Calculation of Forces:**
 Weight of the vehicle,
 $M = 200 \text{ kg}$ (Including one driver.)
 Impact force $F = 1 * G \text{ N} = 1 * G = 1962 \text{ N}$
- **Analysis Results:**

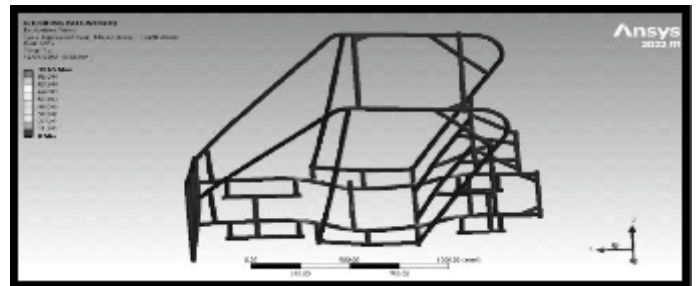

Fig. 20: Stress in bending

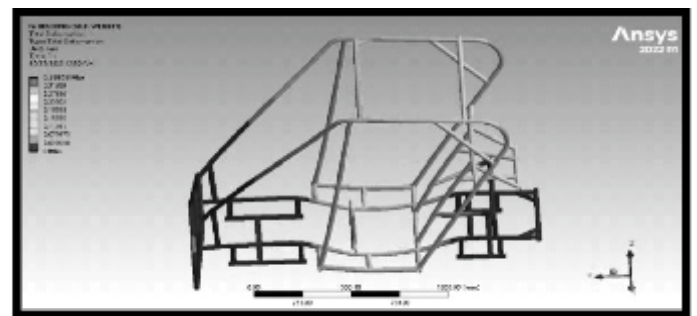

Fig. 21: Bending displacement

Bending due to bump or front bump analysis

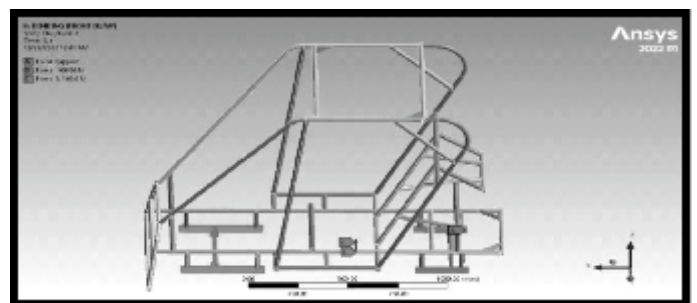

Fig. 22: Nodal force for Front bump Analysis

• **Calculation of impact forces: [10]**

- Radius of bump = 0.1 m
- Hump width = 3.7 m
- Speed = 30 kmph = 8.33 m/s
- Mass of vehicle (with driver),
 $M = 200 \text{ kg}$ Bump = $M * v * r$
 Bump = 166.66 N

• **Analysis Results:**

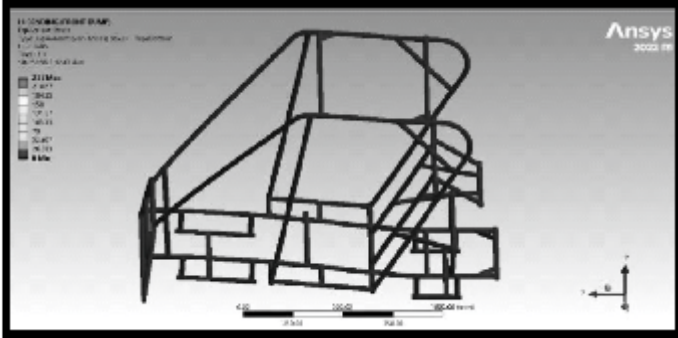

Fig. 23: Front bump Stress

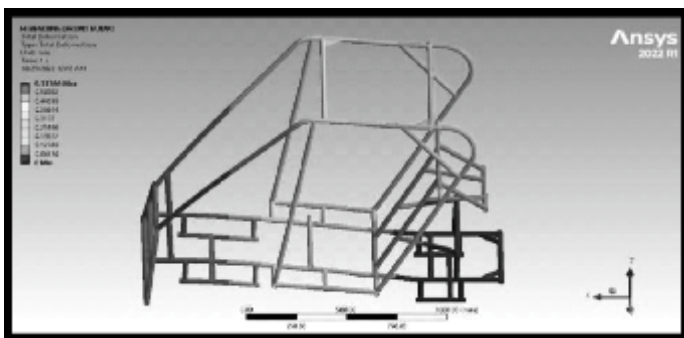

Fig. 24: Front bump Deformation

Bending due to bump or rear bump analysis:

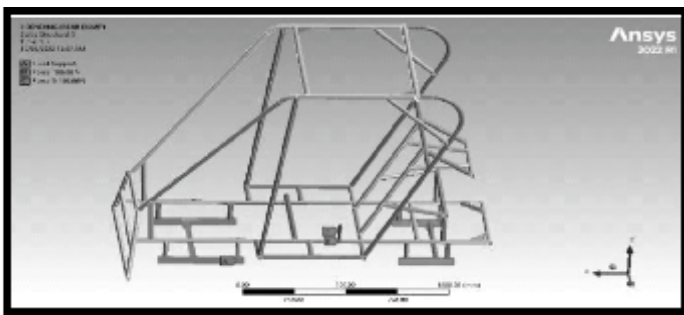

Fig. 25: Nodal force for rear bump Analysis

• **Calculation of impact forces: [10]**

- Radius = 0.1m
- Hump width = 3.7m
- Speed = 30 kmph = 8.33 m/s
- Mass of vehicle (with driver),
 $M = 200 \text{ kg}$ Bump = $M * v * r$
 Bump = 166.66 N

• **Analysis Results:**

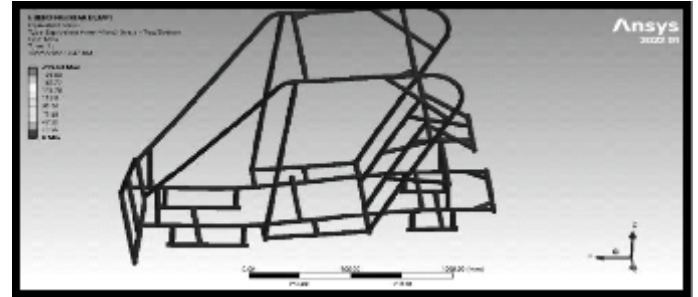

Fig. 26: Rear bump Stress

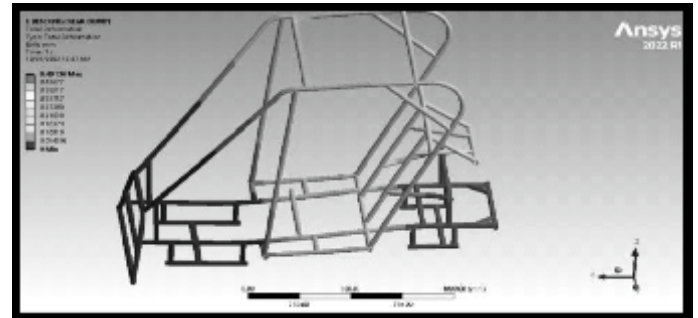

Fig. 27: Rear bump Deformation

6. Torsional Analysis

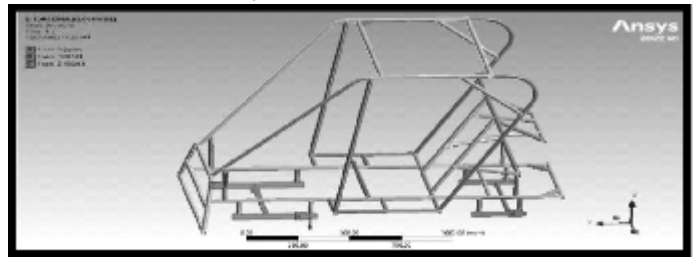

Fig. 28: Nodal force for Torsional(clockwise)

• **Calculation of Forces:**

- Weight of the vehicle,
 $M = 200 \text{ kg}$ (Including one driver.)
 The weight of Effi-que is 60:40 (Rear: Front) so the force transfer from rear to front after applying the brake at the bump will be 60% of total weight.
 Weight on front tire = $0.6 * 200 * 9.81 = 1177.2 \text{ N}$
 A couple is generated which tries to twist the roll cage so the force is applied on tire mounting, hence force on each mounting will be 588.6 N. [10]

• **Analysis Results**

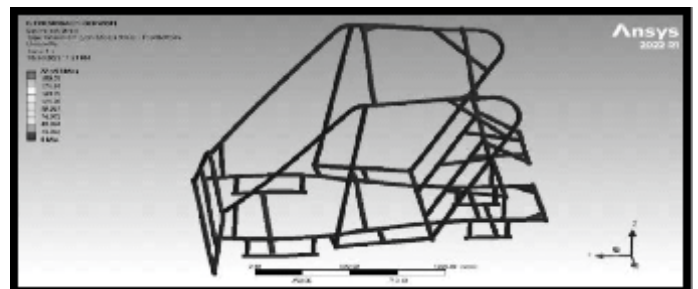

Fig. 29: Torsional Stress (Clockwise)

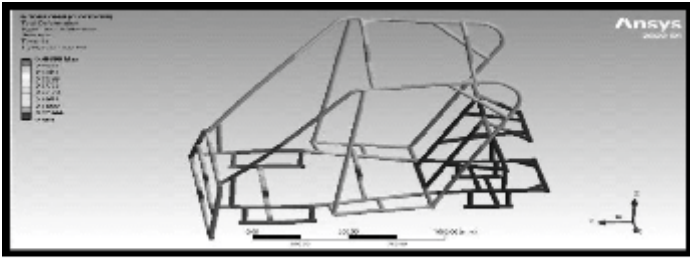

Fig. 30: Torsional deformation (Clockwise)

7. Anti-Clockwise Torsional Analysis:

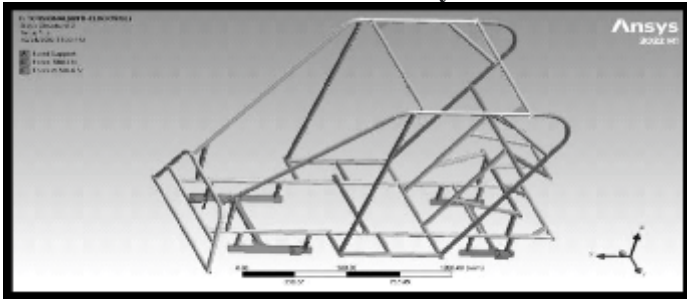

Fig. 31: Nodal force for Torsional(anti-clockwise)

• Calculation of Forces:

Weight of the vehicle,
 $M = 200 \text{ kg}$ (Including one driver.)
 The weight of effi-que is 60:40 (Rear: Front) so the force transfer from rear to front after applying the brake at the bump will be 60% of total weight.
 Weight on front tire = $0.6 * 200 * 9.81 = 1177.2 \text{ N}$

A couple is generated which tries to twist the roll cage so the force is applied on tire mounting, hence force on each mounting will be 588.6 N. [10]

• Analysis Results:

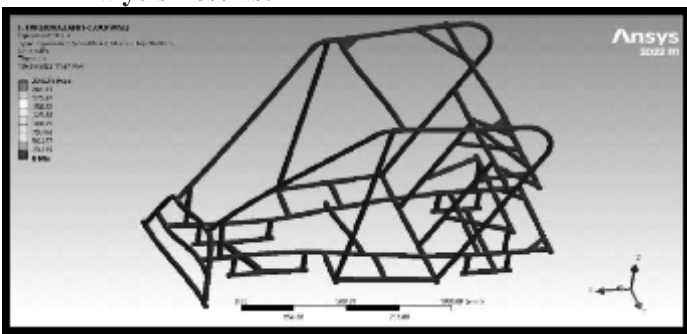

Fig. 31: Torsional Stress (Anti-clockwise)

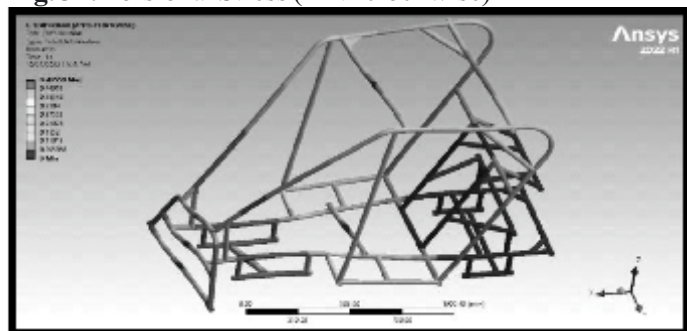

Fig. 32: Torsional deformation (Anti-clockwise)

8. Modal Analysis

Random vibrations are considered non-deterministic motion in mechanical engineering, which means that future behaviour cannot be fully anticipated. The unpredictability, not the mode shapes or natural frequencies, is a property of the excitation or input. Some examples include the load induced on an aeroplane wing during flight, the height of waves on the water, and driving on a bumpy road. Structural response to random vibrations is usually treated as static approach. [4][5][8][9].

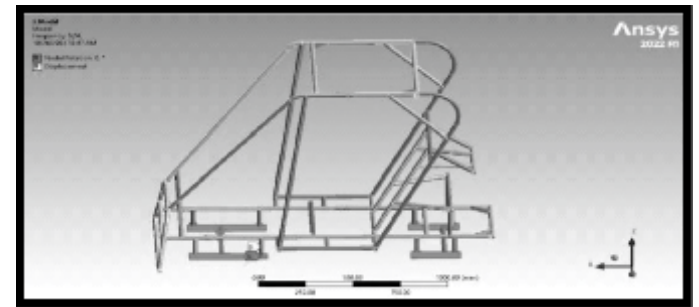

Fig. 33: Nodal force for Hard point

• Analysis Results

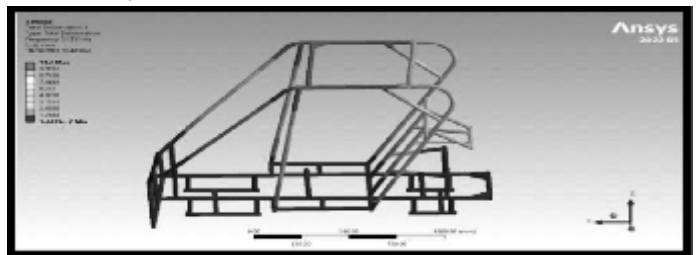

Fig. 34: Mode shape 1

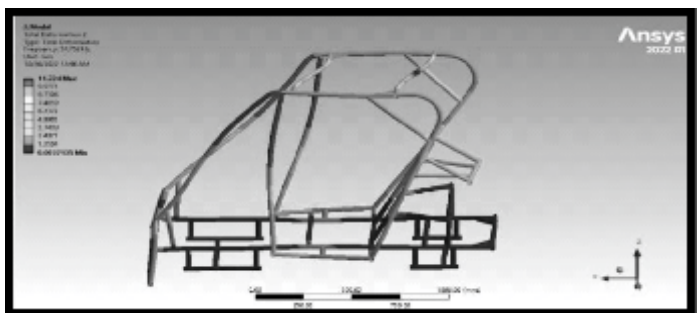

Fig. 35: Mode shape 2

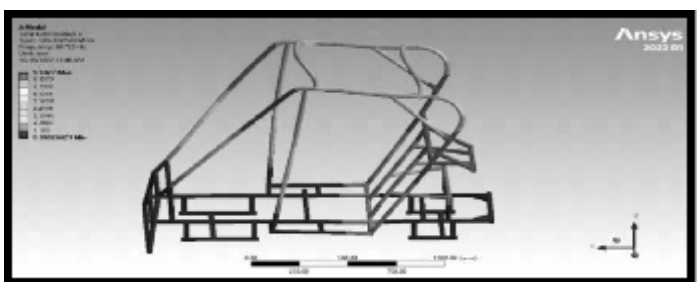

Fig. 36: Mode shape 3

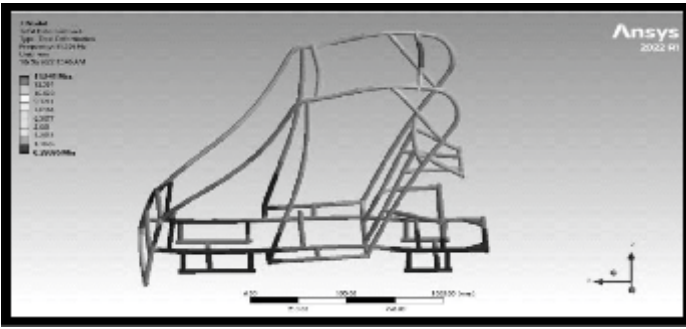

Fig. 37: Mode shape 4

3. Dynamic Analysis

• Assumption & Considerations: As the roll cage was developed by wireframe and then using sweep command to convert the frame to 3D, so every member of roll cage is considered to be properly constrained at every joint. Ansys 2022 R2 is used to create 3D meshing on the frame.

For boundary conditions for dynamic test the roll cage is given the velocity of 30kmph and is crashed onto a rigid wall, where deformation and stress are evaluated to see if it's within the limits. [7]

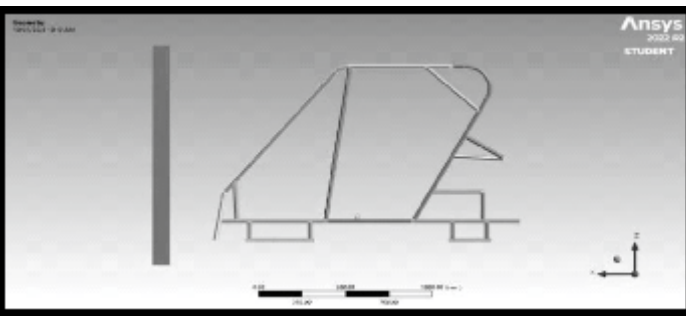

Fig. 38: Dynamic test

Results

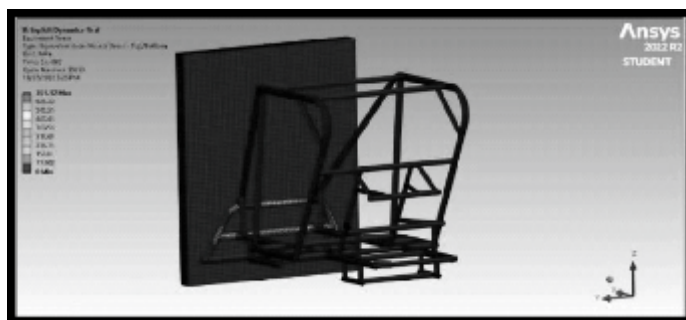

Fig. 39: Stress

D) RESULT TABLE OF ROLL CAGE ANALYSIS

TABLE NO. 3: Final Results

Type	Applied force (N)	Maximum stress (MPa)	Maximum deformation (mm)	F.O.S
Front impact	4584.3	506.49	1.463	1.526
Side impact	4584.3	123.52	0.627	6.26
Rear impact	4584.3	102.65	0.26	7.53
Bending	1962	103.5	0.36	7.47
Modal	-	-	13.841	-
Dynamic	-	701.12	-	1.01

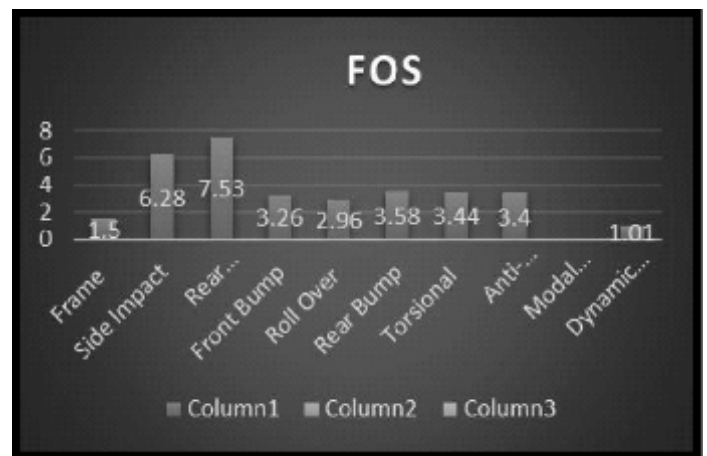

Fig. 40: Factor of safety

D) FINAL MATERIAL SELECTION

Material selected for Frame:
 AISI 4130, Circular type, OD: 25.4 mm,
 ID: 21.4 mm, thickness: 2mm

E) SPACE DISTRIBUTION

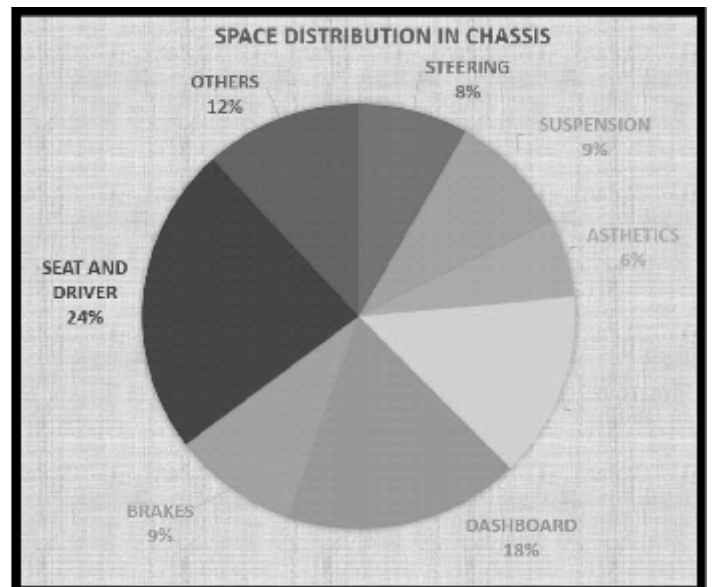

Fig. 41: Space Distribution in Roll Cage

When constructing an electric car, the size of the battery package is undoubtedly a crucial factor. It is essential to have a working cooling system and a solid mechanical mount to guarantee the battery's security and longevity. The placement and mounting style of the battery package are also very important factors in the vehicle's overall design. While the majority of electric vehicles permanently affix their battery packs to the chassis, certain creative designs, like the GOGORO's quickly detachable battery pack, demonstrate that there are other ways to approach this issue.

To obtain the desired bodywork and overall length, the final drive and motor should be tightly packed in the back area of the vehicle. This is crucial for the vehicle's overall appearance and functionality.[1]

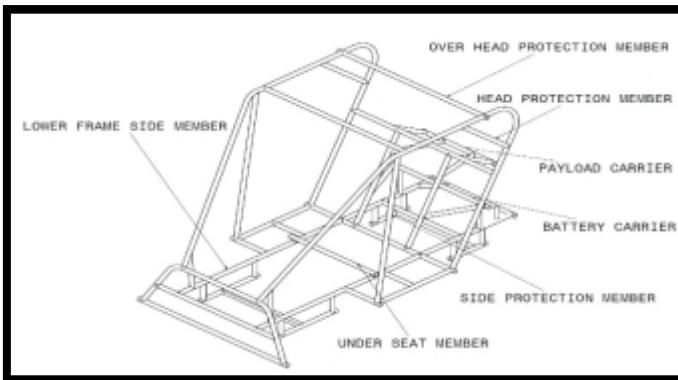

Fig. 42: Vehicle Frame Members

G) CONCLUSION

The final design for the roll cage is achieved by considering various factors such as its design, and various factors such as driver comfort, Rule book criteria, etc. Selection of the material includes cost of material, its availability in market, weight of material, its weldability & strength was taken into consideration.

Three types of iterations were performed for selection of roll cage material, such as AISI 4130, AISI 1018 and EN 19 of wall thickness 2 mm and also 3 iterations to finalize the design. After multiple iterations we found that AISI 4130 is able to sustain all kind of forces and stress in different conditions, its strength is also good and it is available in the market at low cost.

Few optimizations that were achieved are as follows: Reduction in weight, reduction in cost, material availability, reduction in procurement time, improved mechanical properties of roll cage material, proper weight distribution throughout the roll cage.

REFERENCES

- 1) Efficycle SAE INDIA Rulebook 2022.
- 2) Herb Adams, —Chassis Engineeringl, Berkley Publishing Group New York
- 3) Friswell M, Mottershead JE (1995) Finite element model updating in structural dynamics. Springer, Berlin
- 4) Ewins DJ (2000) Modal testing: theory, practice and application, 2nd edn. Wiley, Hoboken
- 5) Jimin He, Zhi-Fang Fu, 8 - Modal analysis methods – frequency domain, Editor(s): Jimin He, Zhi-Fang Fu, Modal Analysis, Butterworth-Heinemann, 2001.
- 6) Aphale, Siddharth & Lachake, Pradnesh. (2017). Design and Analysis of Roll Cage for an Electric Hybrid Tricycle. International Journal of Engineering Trends and Technology.44.72-77.10.14445/22315381/IJETT-V44P215.
- 7) Jithendra Sai Raja, Chada & Akhil, Yuvaraj & GANESH, NATHIPAM. (2021). DESIGN AND ANALYSIS OF AN OFF-ROAD ALL-TERRAIN VEHICLE ROLL CAGE. i-manager's Journal on Mechanical Engineering. 11.10.26634/jme.11.2.17799. <http://www.ijstr.org/final-print/june2014/Free-Vibration-Mode-Shape-Analysis-And-Fabrication-Of-The-Roll-Cage-For-All-terrain-Vehicle-Based-On-Fea-.pdf>
- 8) <https://www.irjet.net/archives/V2/i9/IRJET-V2I9110.pdf>
- 9) <https://www.irjet.net/archives/V7/i5/IRJET-V7I595.pdf>
- 10) <https://www.readcube.com/articles/10.2139%2Fssrn.3439278>

ANALYSING WORK LIFE BALANCE OF ORGANISED & UNORGANISED SECTOR FEMALE WORKERS IN INDIA

Vanshika Sharma

SYBCOM, BCACS, Pune

Email: vanshkhushi2612@gmail.com

Mob: 8228899151

Priya Pawar

SYBBA, BCACS, Pune

Email: priya.pawar@gmail.com

Mob: 7397998119

Arihant Sutar

FYBBA, BCACS, Pune,

Email: arihant17sutar@gmail.com

Mob: 7796690821

Guide : Dr. Prachi Jain - Asst. Professor : Balaji College of Arts, Commerce & Science, Pune | Mob: 8818927757

ABSTRACT

In this global era the corporate world is facing the challenge of increase in business profit and reduction in expenses. This has resulted into tremendous work pressure on the employees. Long working hours, stress due to targets has brought this issue into limelight of work life balance (WLB) into the center-stage in almost all types of employment. In unorganized sector this issue has become worst. Especially for female workers work life balance has become increasingly challenging. Various reports are mentioning about the symptoms like increasing incidences of family disputes, physical and psychological problems indicating lot of unrest among the female workers in India. Although good amount of research studies on WLB is found but for unorganized sector that to female workers was not found during literature review phase. It seems the approach of society is still male dominated and no cognizance is taken of the female working in unorganized sector. This research gap was identified. Hence, descriptive research was considered wherein the data collection was done from 385 female workers from both organised and unorganized sectors of India. Online survey was carried out through various social media platforms wherein snowball sampling method was considered. The findings of current study indicate that there exist vast difference in WLB of organised & unorganized sector female workers and the situation of unorganized sector female worker is very pathetic on WLB front. The outcome of this research work will be useful for the policy makers and corporate world for designing appropriate measures for ensuring work life balance for the female workers.

KEYWORDS

WLB, Work-life, Organised Sector, Unorganized Sector, Female Workers

INTRODUCTION

Due to the growing knowledge economy, an increasing number of females in India are getting empowered due to the opportunity of getting higher education as compared to earlier days. As compared to men, females are required to shoulder additional responsibility of home and caring for their children. In this global era the workplace demands are increasing and have become extremely dynamic. Work

pressure mandates an employees to stay longer at workplace than their homes. On one hand the businesses are scaling newer heights, the employees WLB issue is getting out of control. Symptoms like increased family disputes, divorces, suicides, organizational conflicts etc. are reflections of disturbed employees work life balance. WLB means ensuring positive balance among personal & professional life. In its border sense WLB means involvement of a satisfactory level in multiple roles played by an individual in his life like an employee, father, husband, friend etc. WLB is about creating a healthy and positive work culture in an organization. Work-life balance in females' life plays an important role that makes everything run seamlessly. Therefore in recent years, females have acknowledged managing their hours. In fact, in many ways, women have suffered from anxiety and work stress in both sectors. Unorganized sectors is characterized by maximum women working at low wages due to illiteracy, low level of skills, surplus labor and ignorance and thereby facing more exploitation. Due to which bargaining power of female workers diminishes resulting which future opportunities of development gets infringed. Unorganized sector contributes more than half of the country's GDP. However, unorganized sector is dominated by female workers. Many female workers forgoes their mandatory benefits which could have ensured better WLB for them. WLB concept denotes managing time among work and life requirements. Female workers in both organized and unorganized sectors have to make tough decisions. All the conditions regarding tough decisions depend upon environment of their family eg. Many household wives have responsibility for their kids and old age parents. The working condition of females in a society is dominated by her male counterpart and in some cases family is also non-supportive. Hence balancing work-life becomes challenging for women workers.

RESEARCH GAP:

In unorganized sector this issue of WLB has become worst. Especially for female workers work life balance has become increasingly challenging. Various reports are mentioning about the symptoms like increasing incidences of family disputes, physical and psychological problems indicating lot of unrest among the female workers in India.

Although good amount of research studies on WLB is found but for unorganized sector that to female workers was not found during literature review phase. It seems the approach of society is still male dominated and no cognizance is taken of the female working in unorganized sector. This research work is an attempt to address this research gap.

LITERATURE REVIEW:

Shilpi Kulshrestha (2022) found that female employees in banks experiences frequent headaches and fatigue due to work pressure. Connection between job requirements and stress related health issues like hypertension, anxiety was found. (Hiba Abdullah Alsubhi, Dr. V. Vishnukanth Rao, Umniya Hamed Alhashmi, Muzna Yaqoob Alaamri, Aseel Salim Almahrouqi, Zainab Humaid Alghawi, 2022,) found that many factors affect perception of an employee and work experience as academic staff at university like quality of leadership, teamwork, communication and overall work environment. Ultimately, these factors play a significant role in determining the proportion to which female employees can balance their work and personal lives effectively. A. Vasumathi (2018) found that female workers normally face issues such as sexual and mental harassment in the workplace. Thus although women in the workforce do face significant challenges, there are also significant resources available to support them and help them overcome these obstacles. Amit Verma, Thangjam Ravichandra, Dr. Lakhvinder Kaur, Dr. G. Radha Krishna Murthy (2022) said current challenge for female workers is their work-lifestyle and reward, opportunity for promotion as compared to their male counterpart.

Nwagbara, Uzoechi (2022) highlighted necessity of organizational support for promoting a healthy WLB for employees. Ahmed, Wee Chan Au; Uracha Chatrakul Na AyudhyaTan, ;Yan Soon; Pervaiz K.(2020) ascertained challenges and opportunities for female workers in WLB. Madhusudhanan, R; Subha, B; Thomas, Abraham A. (2021) identified five main factors contributing to occupational stress for women IT employees working from home like: Poor Work Environment, Workload, Personal Problems, Job Insecurity and Lack of Structure. Baral, Rupashree (2020) determined the comparative importance of factors like person-based and situational in estimating conflict of work-family nature. Kaushal, Poonam; Jai Singh Parmar (2019) studied the WLB of police personnel in India, focusing on the age group of 30-35 years and the impact of family commitments on their working life. Dr. Kalpana K. Deshmukh (2018) found that that women experience greater pressure than men in maintaining work-life balance. Dr. V. Vishnukanth Roa (2022) found that employees' inability to participate in research activities and take on responsibilities can generate stress. The study further reveals that female employees often have different

perceptions and attitudes towards their personal and professional lives. In summary, study concluded that WLB is not always embraced by some female employees in organizations.

Research Methodology:

Descriptive study was conducted for this research work wherein data was collected from 385 female worker in India by snowball sampling method by online mode.

Objectives:

1. Ascertaining work life balance of organised & unorganized sector female workers in India
2. Ascertaining relationship among Job satisfaction & WLB of organised and unorganized sector female workers in India
3. Comparative analysis of WLB of organised and unorganized sector female workers in India.

Hypothesis:

H01: Significant difference does not exist in the WLB of organised & unorganized sector workers in India

H02: Significant difference does not exist in relationship among WLB with Job satisfaction of women workers in India

Type of Research: Survey

Objectives of the study are related with ascertaining female worker opinion/perception, hence survey method is appropriate for this research work.

Research Approach: Online/Digital mode

Sample Units: Organised and unorganized sector female worker in India

Sample Size = 385

It is calculated based on the formula described hereunder:

$$\begin{aligned} \text{Sample Size } n &= \{Z^2 * P * Q * N\} / \{[e^2(N-1)] + [Z^2 * P * Q]\} \\ &= \{(1.96)^2 * 0.5 * 0.5 * 264449987\} / \{[(0.05)^2 \\ &\quad (264449986 - 1)] + [(1.96)^2 * 0.5 * 0.5]\} \\ &= 384.15 \end{aligned}$$

Where; e = Margin of Error. Assuming it as 5%

n = Sample Size, N = Population Size = 264449987... number of female worker in India who are currently working in organised and unorganised

Z = Normal Standard Variate...related to degree of confidence (for CL=95%...Z=1.96)

P = An attributes' probable Proportion being available in a population....the data regarding number of female worker in organised and unorganized sector across the country is not available but the information available on www.statista.com mentioned about 50% penetration rate of in India. Hence, it is assumed that P=0.5, Q=1-P

Sampling Procedure: Snowball sampling method

Data Analysis:

Table 1: Demographic Characteristics

		Frequency	Percentage %	Cumulative %
Age	20 – 30 years	150	38%	51.0%
	31 – 40 years	115	29%	80.5%
	41 – 50 years	41	11%	91.0%
	51 – 60 years	35	9%	100.0%
	Unmarried	140	36%	36%
Marital Status	Married	248	64%	99%
	Divorce	2	1%	100%
	Window	0	0%	100%
Education	Below SSC	34	9%	9%
	SSC	12	3%	12%
	HSC	20	5%	17%
	Graduation	162	42%	58%
	Post-Graduation	81	21%	71%
Experience	PG+	81	21%	100%
	Less than 1 year	69	18%	18%
	2 – 5 years	63	16%	34%
	6-10 years	43	11%	100%
	10+ years	103	26%	72%
Working Status	Part time	137	35%	35%
	Full Time	164	42%	77%
	Daily wages	11	6%	86%
	Project based	55	14%	100%

Measures: In this research work we have measured WLB, job-satisfaction and perceived organisational support by using validated scales developed by Brough et al. (2009), Macdonald and MacIntyre (1997) and Eisenberger et al. (1986) respectively on Likert scale. Cronbach's alpha was used to test Internal consistency & Reliability of the scale. Since Cronbach's Alpha > 0.6 the questionnaire are assumed as reliable.

Table 2: Case Processing Summary

	N	%
Cases Valid	385	100.0
Excluded ^a	0	.0
Total	385	100.0

a. List wise deletion based on all variables in the procedure

Table 3: Reliability Statistics

	Cronbach's Alpha	Cronbach's Alpha Based on Standardized Items	No. of Items
WLB	.841	.841	22
Job Satisfaction	.656	.656	10
POS	.703	.703	08

Table 4: WLB & Job Satisfaction Score of Women Employees

	Organised Sector	Un-organised Sector
WLB	2.031	4.104
Job Satisfaction	3.288	4.671
POS	2.341	4.836

Table 4 shows that work life balance of organised sector female workers is better as compared to unorganized sector workers.

Table 5: ANOVA Table:

Source of Variation	SS	DF	MS	F	p
Between Rows	0.8374	r-1=2	MSR=0.4187	2.65	0.2734
Between Columns	5.9024	c-1=1	MSC=5.9024	37.46	0.026
Error(residual)	0.3151	(r-1)(c-1)=2	MSE=0.1576		
TOTAL	7.0549	rc-1=5			

F(2,2) at 0.05 level of significance =19 & Fcal=2.65 Since Ftable > Fcal ..H0 is accepted.

Thus, it is concluded that significant difference does not exist between WLB, Job Satisfaction & POS of organised & unorganized women workers.

Now, F(1,2) at 0.05 LOS =18.5128 & Fcal=37.46 Since Ftable < Fcal H0 is Rejected

Thus, it is concluded that significant difference exist between WLB, Job Satisfaction & POS of organised & unorganized women workers.

Correlation Coefficient (Pearson's): Work life balance ascertained is positively correlated with Job satisfaction & perceived organizational support in case of both organised sector women workers whereas it is reverse in un-organised sector women employees. Thus, null hypothesis No.2 is rejected and it is concluded that significant difference does exist in relationship among WLB and Job satisfaction of female workers in India.

Correlation Table (Organised Sector):

	WLB	Job Satisfan	POS
WLB	1		
Job Satisfn	0.543*	1	
POS	0.473*	0.481*	1

*Pearson correlation coefficient

Correlation Table (Un-organised Sector):

	WLB	Job Satisfaction	POS
WLB	1		
Job Satisfaction	- 0.16*	1	
POS	0.23*	-0.31*	1

Physical & Mental Health issues due to WLB issues:

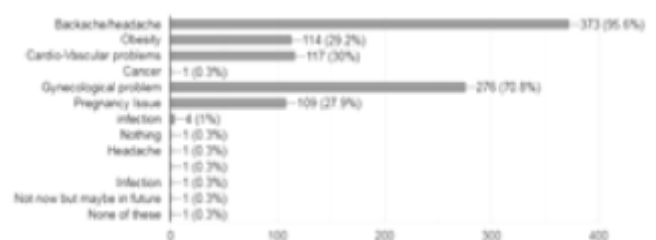

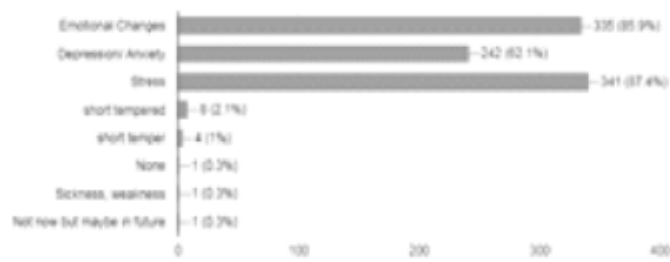

This chart indicate that majority of the physical health problems being faced due to WLB issues by female workers in India are backache/headache & gynecological problems.

This chart indicate that majority of the psychological health problems being faced due to WLB issues by female workers in India are emotional misbalance, depression/anxiety and stress. Mostly married female workers working in private sector faces these health problems very frequently.

Conclusion:

In this era of global competition management gurus and thinkers across the world are concerned about WLB of employees since it has its strongest impact on the employee efficiency. This has resulted into tremendous work pressure on the employees resulted into very serious issue of work life balance for the workers. This issue is very serious for unorganized sector female employees in India. This research study has found that vast difference exist in work life balance of organised & unorganized sector female workers in India & the situation of unorganized sector female workers is very pathetic. The relationship of WLB, Job Satisfaction and POS is positive in case of organised sector female employees whereas it is negative in case of unorganized sector female workers. It is found that majority of the health problems being faced due to WLB issues by private sector working- married female workers in India are backache/headache, gynecological problems, emotional misbalance, depression/anxiety and stress.

Directions for Future Research:

This research aims at analyzing the WLB of female employees in general. But the situation of WLB may vary in different sectors of the economy. It is generally seen that if case of the concerned Govt. is not vigilant society's weaker sections gets exploited. Female workers are vulnerable for this type of exploitation. For a progressive society and a democratic country, it is important to ensure empowerment of marginalized and weaker sections of the society. Hence, micro level studies may be conducted in various parts of the world as well as in different sectors of economy so that factual situation can be known to the people and appropriate government rules & policies may be designed for their betterment.

Bibliography:

- 1) Arunkumar Dubey, S. Riasudeen (2021), 'Does Work-Life Balance Mediate the Relationship of Perceived Organizational Support and Job Satisfaction for Healthcare Workers? A Study on Female Nurses in India', *NMIMS Management Review*, Volume XXIX, Issue-3, pp 96-103.
- 2) Thilagavathy S., Geetha S. N. (2021), 'Work-life balance: A systematic review', *XIMB Journal of Management*, Emerald Publishing Limited.
- 3) N. Divya Jaya Lakshmi (2018), 'A Study of Work life balance of Women employees in selected organisations- an empirical study', *JETIR*, Volume 5, Issue 6, 2016 *International Research Journal of Management and Commerce*, Vol.3, Issue 12, ISSN(2348-9766).
- 4) Shilpi Kulshreatha (2022), 'A descriptive Study on Work Life Balance of Women Employees in Banks', *International Journal of Economics and Management*, Vol 6(3), ISSN:2278-2478.
- 5) Dr.V.Vishnukanth Rao, Hiba Abdullah Alsubhi, Umniya Hamed Alhashmi, Muzna Yaqoob Alaamri, Zainab Humaid Alghawi, Assel Salim Almahrouqi (2022), 'A study on the Work-life Balance of Female Employees at University in Sultanate of Oman, 2022', *Saudi Journal of Business and Management Studies*, ISSN:2415-6663
- 6) Vasumathi A (2018), 'Work life balance of employees', *International Journal of Services and Operations Management*. 2018, Vol. 29, No.1, Research Gate
- 7) Dr. Kalpana k. Deshmukh (May 2018), 'Work-life balance study focused on working women', Vol. 5 (Iss.5): May 2018] ISSN: 2454-1907 DOI: 10.5281/zenodo.1296934.
- 8) Dr. Saloni Pahuja (2022), 'Work life balance of females employees: a case study', *International Research Journal of Management and Commerce*, Vol.3, Issue 12, ISSN(2348-9766).
- 9) Thangjam Ravichandra, Dr. G. Radha Krishna Murthy, Amit Verma, Dr Lakhvinder Kaur (2022), 'A study on work-life Balance of a Female Employee in Indian Industry', *International Journal of Special Education* Vol.37, No.3, 2022. Subha, B
- 10) Madhusudhanan, R; Thomas, Ajai Abraham (Jun 2021), 'An Investigation of the Impact of Occupational Stress on Mental health of remote working women IT Professionals in Urban Bangalore', *Journal of International Women's Studies*; Bridgewater Vol.22, Iss.6, pp. 139-149. Baral, Rupashree
- 11) (2020), 'Comparing the situation and person-based predictors of work-family conflict among married working professionals in India', *Baral, Equality, Diversity and Inclusion: An International Journal*; Birmingham Vol.39, Iss.5, (2020): pp. 479-495.

- Kaushal, Poonam
- 12) Jai Singh Parmar (2019), 'Work-Life Balance and Its Relation to Demographic Factors: A Study of Police Personnel of Himachal Pradesh', *Journal of Strategic Human Resource Management*; New Delhi, Vol.8,Iss.1
 - 13) Wee Chan Au, Uracha Chatrakul Na Ayudhya ,Tan ,Yan Soon, Ahmed ,Pervaiz k (2020), 'The work-life experiences of an invisible workforce: The case of live-in women migrant domestic workers in Malaysia, Equality', *Diversity and Inclusion: An International Journal*, Vol. 39, Iss.5, pp. 567-583.
 - 14) Nwagbara, Uzoechi (2022), 'Institutions and organisational work-life balance (WLB) policies and practices: Exploring the challenges faced by Nigerian female workers', *Journal of Work-Applied Management*; Bingley Vol.12,Iss.1,pp.42-54.
Uddin, Mahi
 - 15) ;Ali, Kalsom Binti; Khan, Mohammad Aktaruzzaman (2020), 'Impact of perceived family support, workplace support, and work-life balance policies on work-life balance among female bankers in bangladesh', *International Journal of Economics, Management and Accounting*, Petaling Jaya Vol.28,Iss.1, pp.97-122.
Rahman Mushfiqur
 - 16) Chima Mordi; Emeka Smart Oruh; Nwagbara, Uzoechi; Tonbara Mordi; et al (2018), 'The impact of work-life-balance (WLB) challenges on social sustainability: The experience of Nigerian female medical doctors',*Employee Relations*; Bradford Vol.40,Iss.5, pp. 868-888.
Solanki, Sandip
 - 17) Mandaviya, Meeta (2021), 'Does Gender Matter? Job Stress, Work-Life Balance, Health and Job Satisfaction among University Teachers in India', *Journal of International Women's Studies*;' Bridgewater, Vol. 22, Iss. 7, pp. 121-134.
Chaudhuri, Sanghamitra
 - 18) Arora, Ridhi; Roy, Paramita (2020), 'Work–Life balance policies and organisational outcomes– a review of literature from the Indian context', *Industrial and Commercial Training*; Guilsborough, Vol.52,Iss.3, pp. 155-170.
Fung, Louis Ka-hei
 - 19) Hui Ray Tak-yin; Yau, Wally Chi-wai (2021), 'Work-life balance of Chinese knowledge workers under flextime arrangement: the relationship of work-life balance supportive culture and work-life spillover', *Asian Journal of Business Ethics*; Dordrecht, Vol.10,Iss.1, pp. 1-17
Merlin Mythili Shanmugam
 - 20) Agarwal, Bhawna (2019), 'Support perceptions, flexible work options and career outcomes: A study of working women at the threshold of motherhood in India', *Gender in Management*; Bradford Vol.34,Iss.4, pp. 254-286.
Kar, Brajaballav
 - 21) Panda, Madhu Chhanda; Pathak, Mallika Devi (2019), 'Women's Work-Life Balance: Compensation is the Key', *Journal of Management Research*; New Delhi Vol.19,Iss.1, pp. 29-40.
Munyeka, Wiza
 - 22) Maharaj, Ashika (2022), 'A quantitative study on salient work-life balance challenge(s) influencing female information and communication technology professionals in a South African telecommunications organization', *SA Journal of Human Resource Management*; Tygervalley Vol.20
Maurya, Kamlesh Kumar
 - 23) Agarwal, Manisha; Srivastava, Dharendra Kumar (2021), 'Perceived work-life balance and organizational talent management: mediating role of employer branding', *International Journal of Organization Theory and Behavior*; Boca Raton Vol.24,Iss.1, pp. 41-59.
 - 24) Chaudhuri, Sanghamitra; Arora, Ridhi; Roy, Paramita (2020), 'Work-life balance policies and organizational outcomes– a review of literature from the Indian context', *Industrial and Commercial Training*; Guilsborough Vol. 52, Iss. 3,pp. 155-170.
 - 25) Vijayraghavan, Kala; Bhatt, Shephali (2021), 'Not an Easy Transition: additional expectations 'unique challenges' Many mid-level female employees seek to return to office as their work-life balance goes for a toss', *The Economic Times (Online)*; New Delhi, 13 Mar 2021.
Poulose, Shobitha; Dhal, Manoranjan (2020), 'Role of perceived work–life balance between work overload and career commitment', *Journal of Managerial Psychology*; Bradford, Vol.35,Iss.3, pp. 169-183.

ADOPTION & USAGE OF ONLINE PAYMENT APPS BY MARGINALIZED COMMUNITIES IN PUNE DIST.

Manya Basrani

SYBCOM student, BCACS, Pune
Email: manyabasrani18@gmail.com
Mob: 9993649527

Muskan Kumari

SYBBA student, BCACS, Pune
Email: muskanrt003@gmail.com
Mob: 9576213836

Priyanka Singh

SYBBA student, BCACS, Pune
Email: priyankasingh827.01@gmail.com
Mob: 8271859447

Abstract:

Growth & development of any country is possible through a balanced financial development of all the sections of the society. Financial empowerment of marginalized sections of the society is essential for the growth of India's economy. Usage of digital technologies for financial empowerment of marginalized sections of the society can be of great importance for Indian economy. In these days online payment apps like Google pay, Phone pay etc. are taking the financial market with storm. In India mobile payment apps market has reached to \$1.9 billion in year 2021 and is expected to reach at \$4.8 billion in year 2025 with a growth of 27% annually. Many research studies are conducted on the topic of online payment apps but no research study is found on the topic of usage of online payment apps by marginalized communities in Pune Dist. This research gap was identified and it was decided to ascertain the adoption and usage of online payment apps by marginalized sections of the society. This research work found that awareness of online payment apps is 81% but adoption is only 31% among marginalized community. The adoption rate increases with increase in education level and income of respondents. Universal acceptability of app, operating convenience and additional financial services are important factors for ensuring apps adoption by the community. The outcome of this study will be helpful for the policymakers and online apps companies for designing appropriate strategies to ensure financial empowerment of this neglected section of the society thereby contributing to the overall growth of the national economy.

Keywords:

Digitalized, telecommunication, proliferation, technology adoption, revolution, Marginalized

Introduction:

In today's digital world every walks of life is getting affected by digital technologies. Financial sector is also witnessing the said transformation wherein the technology is trying to encompass all sections of the society. Online payments apps is one such initiative which is transforming the sector like anything. Due to its inclusive nature Govt. of India is promoting this digital transformation which has got many advantages. E-Governance is like boon to the people.

But, it won't be successful without reciprocation from the other stakeholders like citizens, industry, Govt. machinery etc.

Economy of any nation can prosper only if all the sections of the society contributes towards nation building. For this to happen it is necessary that entire sections of the society are economically empowered so that each one of them will initiate economic activities leading towards economic development of the country. In the country like India presence of economically poor and marginalized communities are very significant. Since, these communities are not economically empowered their contribution towards nation building is not recognized resulting into their neglect and loss of country's human resources capacity.

The term 'Marginalization' describes the tendency of mob, where humans look on undesirable function are omitted ie. marginalizes. Various studies have shown that in India the state of poverty, inequality is high among various category of people like SC, ST, NT. Marginality is an occurrence which influence numerous of human kind right through the globe. Individuals who are marginalized own relative power over their lives and the reservoir accessible to them. A brutal circle is established where by their insufficiency of productive and sympathetic relationship express that they are preclude from getting involved in civic life, which in turn provide a route to further segregation.

Now a days, the cyber payment application enjoyer are increasing exponentially & preference of people in receiving/making payment has alterered in the direction of easiness out in nearby area. The consumers are highly valuable & fulfillment for payment apps. "Digital India" go on a flagship program of Govt. of India which is characterized by "faceless, Paperless, Cashless" nature of activities and transactions. Online payments apps like Google pay, Phone pay, Bhim etc. are steps in the direction of empowering people economically so that quick and appropriate financial decisions can be taken by them.

Pune is an economically emerging city, which is giving shelter to many people including marginalized communities. Proportion of marginalized communities in the city are quite significant. But their social exclusion leads them in remaining poor and resource less. They are denied access to many institutions like banking services.

Many factors can conduct to this contradiction of access to foundations and scopes, including historical unfairness and deficiency of funding. Marginalization arise due to cultural, gender, sexual adaptation, disability repute, social economic measure and age. These categories are often at a drawback when it comes to acquiring health care, competent education, and employment that would upgrade their prosperousness.

Research Gap:

Online payments markets across the world is steadily growing. In India mobile payment apps market has reached to \$1.9 billion in year 2021 and is expected to reach at \$4.8 billion in year 2025 with a growth of 27% annually. Many research studies are conducted on the topic of online payment apps but no research study is found on the topic of usage of payment apps(online) by marginalized communities in Pune Dist. This research gap was identified and it was decided to ascertain the adoption and usage of online payment apps by marginalized sections of the society.

Literature review:

- “Kaur, Puneet, et al (2020)” examined the trend of mobile wallet apps is being increasing rapidly. Even though transaction through these wallets are safe and convenient the market is not reciprocating proportionately.
- “Ghosh, Gourab (2021)” said development digital technologies especially ICT has laid the foundation of modern payment methods of online payment apps. Digitization has improved the pace of trade and commerce by making the transaction/payment fast and secure.
- “Pillai, Sruthy, S.G. Sandhya & G. RejiKumar (2019)” said tendency show that populace favour utilizing the non-cash notes while money scarcity was at hir crest on par for minor transaction import. . Humans are more worried about safety outlook as they postulate that their budgetary details neither risk free though performing online proceeding.
- “Mishra, Sonal & Kirti R. Swain (2018)” said e-gadgets structure has procure admiration in the latterly, because of increase smart phone perforation, reasonable velocity online connectivity; crave for quick payment accommodation but the proportion enlarge is yet not acceptable, In spite huge efforts built by Govt accelerate to digital literacy.
- “Pal, Abhispa, Tejaswini Herath , H. Raghav Rao (2020)” said commerciality of e-banking services depends on appropriate transactions as per users requirements. In the progressing cyber-crime, nevertheless, mobile payment transactions take risk of fiscal and information leakage. Therefore, it is important to know how convenience of transaction &

risk influences users usage intentions for these payment apps.

- “Kavita, M., K. Sampath Kumar (2018)” said digital payments in India are increased tremendously after demonetization. Horizon of digital payments are increasing due to GOI initiative like 'Digital India' campaign. Various innovative tools like digital wallets, UPI, payment apps are being used in these days for easy transaction.
- “Gupta, Rahul, Cheshtha Kapoor, Jayesh Yadav (2020) said Govt. initiative of 'Digital India' aims at strengthening knowledge economy by way of digital empowerment. Since, India is aspiring for becoming an economic superpower, various innovative financial tools like e-wallets, ATM, Credit cards, UPI etc. will make its path easy.
- “Anshari, Muhammad, et al (2021)” said e-wallet concept will improve the performance of financial institutions and will pave the way for addition of various new services to ensure convenience to customers. Youngsters really like these payment apps which has made financial transaction easy and fast.
- “Dr S. Manikandan may (2017)” said high-tech development has made smartphones as were gadgets the mobile customer can make fiscal transactions by using applications downloaded in phones. This study explained about application of wallet money and factors affecting use of the same by the consumers.
- “Nair, Amal, Manisha Dahiya, Naman Gupta (2016)” said people are using wallet since generations together to protect & carry their personal items. In the earliest form cloath bags were used to carry personal belonging. Human being was always mobile/migrating from one place to other. Hence, he was using wallets. In this digital era people should make use of e-wallets to carry digital currency.
- “Mishra, A.B (2020)” said in this digital era various wireless offers are increasing quantity-wise and quality-wise. Businesses have started realizing that digital platform is necessary for ensuring the efficiency of their business. E-transactions are being used by majority of the businesses in these days.
- “Singh, Sindhu (2020)” said penetration of smartphones in the society has resulted in enhancing the acceptability of mobile payments. Acceptance rate, initial acceptance & post acceptance satisfaction etc. are interesting topics to understand consumer behavior towards mobile payments.
- “Djauhari, Medina Juniar, Chairul Furqon, Mokh Adib Sultan (2020)” examined go-pay payment app and found it as very innovative tool. Study aimed at ascertaining customer intention to use app.
- “Das, Abhrajyoti, et al. (2018)” said digital wallets are convenient ways of transaction. Various payments apps like Jio money, Paytm, Airtel money etc are very

- popular apps for safe and speedy transaction.
- “James Joseph, K.V. Shriram, Lawlyn L.R. Rodrigues, Ashish Oommen Mathew K.C. Gana (2018)” found major attractions for customers for usage of mobile apps as cashbacks, simple use, services etc. Study further found that awareness regarding digital payments is high in urban areas compared to rural areas.
- “Rahul Gochhwal (2017)” said these mobile payments apps will be so popular in future that every small retailer will use it and the necessity of intermediaries will vanish.
- “Priyanka. S .Kotecha (2018)” said digital payments are the main mode of transactions for many retailers in India and the sector of digital payment will experience tremendous growth in times to come.
- “Zlatko Bezhovski (2016)” : said digital payment apps will grow exponentially in future and customer will get tremendous benefit from it.

Research Methodology:

Descriptive study was conducted for this research work wherein data was collected from 385 marginalized community citizens in Pune Dist. by snowball sampling method.

Objectives:

- 1) This ascertain level of awareness & adoption of online payment apps by the marginalized communities in Pune Dist.
- 2) To analyze factors affecting usage of online payment apps by the marginalized communities in Pune Dist.
- 3) To analyze effect of demographic factors on usage of online payment apps by the marginalized communities in Pune Dist.

Hypothesis:

H01: Significant difference does not exist in the awareness & adoption of online payment apps of marginalized community people in Pune Dist.

H02: Significant difference does not exist in the usage of online payment apps and demographic variables of marginalized community people in Pune Dist.

Research Design: This is a descriptive research wherein primary data was collected from 385 citizens belonging to marginalized community in Pune Dist.

Type of Research: Survey. Objectives of the study are related with ascertaining the usage & adoption of online payment apps by the people hence survey method is appropriate for this research work.

Research Approach: Personal survey was done since the nature of topic was related with usage of digital platform for financial transaction. Hence, to avoid bias it was though

that online survey should be avoided.

Sample Units: People of marginalized communities in Pune dist.

Sample Size = 385

It is calculated based on the formula mentioned below:

The size of sample

$$n = \frac{Z^2 * P * Q * N}{\{e^2(N-1)\} + \{z^2 * P * Q\}}$$

$$= \frac{\{(1.96)^2 * 0.5 * 0.5 * 31,24,498\}}{\{(0.05)^2 (31,24,498)\} + \{(1.96)^2 0.5 * 0.5\}}$$

$$= 384.15$$

Where

e = Error margin, assuming it as 5%

n = Sample Size

N = Size of the population = 31,24,498 (Maharashtra Population (Source: Census 2011))

Z = Normal Standard Variate...related to degree of confidence (for CL = 95%...Z = 1.96)

P = Attributes' estimated Proportion being present in population, the data regarding number of people belonging to marginalized community in Pune Dist. is assumed as 50%. Hence, it is assumed that P = 0.5, Q = 1 - P

Sampling Procedure: Snowball sampling method

Research Instrument: Structured questionnaire

Data Analysis:



Pie Chart shown above exhibit that although the awareness level among the people of marginalized community is high i.e. 81% but the adoption rate is only 31%.

Validity & Reliability testing of Questionnaire:

Data collection was carried out using an appropriate questionnaire. The questionnaire consisted of 2 parts. First part included general open ended questions. Second part of questionnaire was meant for measurement of factors affecting usage and adoption of online payment apps through 5 point Likert Scale. After designing the questionnaire pilot survey was conducted on 10 respondents so that terms and questions which are ambiguous or sounds different meaning can be modified. Accordingly few questions were modified thereby establishing the valid content. Alpha Cronbach's was useful for verifying the reliability of questionnaire. The reliability analysis of part 2 of questionnaire i.e. factors affecting usage & adoption of online payment apps is: Since Cronbach's Alpha > 0.6 Reliability of the questionnaire is established.

Table 3: Reliability Statistics

	“Cronbach's Alpha”	“Cronbach's Alpha Based on Standardized Items”	No. of Items
Usage of Online Payment Apps	.7248	.724	12

	Usage-Yes	Usage- No
Male	97	190
Female	35	99

Table 1: Descriptive Statistics

Education	Count	Income	count	Age	Count	Gender	Count
Illiterate	32 (8.26%)	Less than 14K	61 (15.76%)	13 to 19	101 (26.09%)	Male	264 (68.21%)
Primary	63 (16.27%)	15K to 100K	83 (21.44%)	20 to 30	162 (41.86%)	Female	123 (31.78%)
Below SSC	101 (26.09%)	101K to 500K	99 (25.58%)	31 to 40	87 (22.48%)		
SSC to HSC	67 (17.31%)	501K to 1000K	99 (25.58%)	41 to 50	33 (8.52%)		
Graduation	89 (22.99%)	1001K Above	45 (11.62%)	50+	4 (1.03%)		
PG+	35 (9.04%)						
TOTAL	385		385		385		385

Table 2-Online Payment Apps: Awareness Vs. Adoption

	Awareness about App-Yes	Awareness about App-No
Adoption of Apps-Yes	132	23
Adoption of Apps- No	289	193

The chi-square statistic is 33.2414. The p-value is < 0.00001. Significant at $p < .05$. χ^2 (Table < Cal.) Table=3.84 H0 is Rejected $P = 8.14e-9 p < LOS$

It is concluded that significant difference exist in awareness level & adoption of online payment app by the people of marginalized community in Pune Dist.

Age	Usage-Yes	Usage- No
13 to 19	37	74
20 to 30	56	133
31 to 40	26	58
41 to 50	11	22
50+	2	2
TOTAL	132	289

Income	Usage-Yes	Usage- No
Less than 14K	1	67
15K to 100K	3	89
101K to 500K	35	74
501K to 1000K	61	46
1001K Above	32	13
TOTAL	132	289

Education	Usage-Yes	Usage- No
Illiterate	1	36
Primary	3	63
Below SSC	27	79
SSC to HSC	34	38
Graduation	53	44
PG+	14	29
TOTAL	132	289

Table 4: Null Hypothesis (H0) Testing:

Demographic Variables	Chi- Square χ^2	P	Result
Gender	Cal.=2.5, Table=3.84 χ^2 (Table > Cal.)	0.11 (P > LOS)	H ₀ Accepted
Age	Cal. =1.175, Table=9.488 χ^2 (Table > Cal.)	0.88 (P > LOS)	H ₀ Accepted
Income	Cal.=127.74, Table= 11.07 χ^2 (Cal > Table)	0 (P < LOS)	H ₀ Rejected
Education	Cal.= 70.74, Table= 11.07 χ^2 (Cal > Table)	0 (P < LOS)	H ₀ Rejected

Thus, from table 4 it can be concluded that adoption & usage of online payment apps does not significantly differ with respect to Gender & Age of the people of marginalized community in Pune Dist. whereas it differs significantly with respect to Income & education of the people.

Factor Analysis:

Table 7: KMO and Bartlett's Test		
Kaiser-Meyer-Olkin Measure of Sampling Adequacy.		.716
Bartlett's Test of Sphericity	Approx. Chi-Square	2675.439
	Df	66
	Sig.	.000

The conditions followed justifies the use of factor analysis in this case:

- 1) Factor analysis fits in current data because the KMO statistics value exceeds 0.5.
- 2) Sphericity test of Bartlett's shows that the value of 'p' is smaller than 0.05, the assumed level of significance indicating significance of correlation matrix.
- 3) The sample size is 385 which is more than 5 times the number of variables.

Table-8: Communalities

	Initial	Extraction
OPF1: Security from Fraud	1.000	.211
OPF2:Lower Transaction Cost	1.000	.631
OPF3:Safe Transaction with Feedback	1.000	.555
OPF4:Wide Acceptance of Mobile money	1.000	.723
OPF5:Hassle-Free Transaction	1.000	.576
OPF6:Convenience	1.000	.783
OPF7:Fast	1.000	.415
OPF8:Loan(Overdraft) if required	1.000	.755
OPF9:Multiple Services like deposit, withdrawal, investment, MF etc.	1.000	.772
OPF10:Prompt Customer care facility	1.000	.643
OPF11:Simple App i.e. it does not require Hi-end Smart Phone	1.000	.550
OPF12:Should work 24X7	1.000	.581

Table 9: "Total Variance Explained"

Initial Eigenvalues			Extraction Sums of Squared Loadings		
Total	% of Variance	Cumulative %	Total	% of Variance	Cumulative %
5.630	46.121	46.121	5.830	46.121	46.121
1.661	13.840	60.760	1.661	13.840	60.760
.143	7.860	68.620			
.801	6.678	75.211			
.718	5.181	81.271			
.545	4.543	85.822			
.492	4.102	81.124			
.365	3.041	12.164			
.217	2.477	15.441			
.243	2.027	17.467			
.172	1.430	18.897			
.132	1.103	100			

Method of Extraction: Principal of Component Analysis.

Rotated Component Matrix

	Component	
	1	2
OPF1: Security from Fraud	.422	.336
OPF2: Lower Transaction Cost	.471	.641
OPF3: Safe Transaction with Feedback	.333	.667
OPF4: Wide Acceptance of Mobile money	.821	.222
OPF5: Hassle-Free Transaction	.745	.148
OPF6: Convenience	.883	.040
OPF7: Fast	.592	.253
OPF8: Loan(Overdraft) if required	.107	.862
OPF9: Multiple Services like deposit, withdrawal, investment, MF etc.	.010	.871
OPF10: Prompt Customer care facility	.620	.501
OPF11: Simple App i.e. it does not require Hi-end Smart Phone	.606	.428
OPF12: Should work 24X7	.761	.101

Thus, the above table indicates extraction of two factors i.e. 'Universal acceptability & Convenience' which counts up to 46.12% of total variance. Second factor may be extracted by considering remaining factors having higher variances like Facility of overdraft and multiple services which accounts for 13.84% variance.

Factor 1: OPF 4, OPF 5, OPF 6...this factor may be called as 'Universal acceptability & convenience'

Factor 2: OPF8, OPF9,...This factor may be called as 'Financial Services'

Conclusion:

In this global era which is signified by digital revolution online payment apps market is growing steadily. Various governments, citizens and institutions across the world are reaping its benefits. But the question before the researcher

was whether this online payment apps ensure financial inclusion in the sense that whether its benefits are percolating among the lower strata of the society or not. This research work found that usage of online payment apps is more among the age group of 20 to 30 years followed by teenage users in marginalized community in Pune dist. Further, it is also found that proportion of male is more than the female in using these apps. It is also found that the usage of apps increases with education level and income of the people of marginalized community. In regards to the adoption & usage of online payment apps it is found that the same does not significantly differ with respect to Gender & Age of the people whereas it differs significantly with respect to Income & education of the people. Factors responsible for adoption & usage of online payment apps are its universal acceptability, operating convenience & extra financial Services.

Direction for Further Research:

The scope of this study was limited to the Pune district only. Generalization may be possible if similar study conducted on larger geographic area. Similar studies may also be conducted at micro level i.e. at the level of communities so that appropriate penetration strategies may be designed for them.

Bibliography:

- Kaur, Puneet, et al (2020): "Why do people use and recommend m-wallets ?," Journal of Retailing and Consumer Service, Elsevier, volume 56(C).
- Gosh, Gourav (2021): Adoption of digital payment system by customer: A review of literature, 2021 IJCRT volume 9, issue 2 February 2021, ISSN: 2320-282
- Pillai, Sruthy S., Sandhya, and G. Rejikumar (2019): Acceptance of mobile payment and UPI technology-Indian context volume 5 no.3 December 5, 2019 pp 371-385
- Mishra, Sonal, and Kirti R. Swain (2018): A study on uses of online payment apps by customer 2021 IJCRT, volume 9, issue 5 May 2021, ISSN: 2320-2882
- Pal, Abhispa, Tejaswini herath and H.Raghav Rao (2020): Is the Convenience worth the risk? An Investigation of mobile Payment Usage, published on: 8 October 2020, Information system frontiers 23, 941-961 (2021)
- Kavitha, M., and K. Sampath Kumar: A Study on digital payments system with perspective of customers adoption, Eurasian journal of analytical chemistry, ISSN:1306-3057, open access 2018 13 (SP):189-200
- Gupta, Rahul, Cheshtha Kapoor, and Jayesh Yadav (2020): Acceptance towards digital payments and improvements in cashless payment eco-system. Published in: 2020 international conference for

Emerging (INCET), date of conference 05-07 June 2020

- Anshari, Muhammad, et al (2021): Factors influencing individual in adopting e-wallet, published: 05 January 2021, journal of financial service marketing 26,10-23 (2021)
- Dr. S. Manikandan may (2017): An empirical study on consumers adoption of mobile wallet with special reference to Chennai city, May 2017, International journal of research - Granthaalaya 5 (5):107-115
- Mishra, A.B (2020): Expanding mobile wirele4ss capacity: The challenges presented by technology and economics, Tele-communication policy volume 38, issues 8-9, September 2014, pages 693-708
- Singh, Sindhu (2020): Project: Transformation of Indian Economy- approaches through alternate media digital technologies July 2009. Turkish online journal of distance education 10(3):32-41
- D Jauhari, Medina Juniar, Chairul Furqon, and Mokh Adib Sultan (2020): Analyses quality-technology acceptance modal (QTAM) Pada mobile payment system Go-Pay, Medina Juniar D Jauhari, 2020.
- Das, Abhrajyoti, et al (2018): Gaps in customer satisfaction with digital wallets :challenge for sustainability, journal of management development, Publication date: 25 June 2018, ISSN:0262-1711.
- Nair, Amal, Manisha Dahiya, and Naman Gupta (2016): International Journal of research Educating customers about digital wallet, volume 03, issue 13 September 2016, p-ISSN:2348-6848
- James Joseph, K.V. Shriram, Lawlyn L.R. Rodrigues, Ashish Oommen Mathew and K.C. Gana (2018): A empirical study on customer adoption of mobile payment application in India, August 2018: International Journal of Enterprise Network management, Volume 09 (Nos. 3/4): 363-375.
- Rahul Gochhwal (2017): Unified Payment Interface- An Advancement in Payment Systems, Indian Institute of Management, Calcutta, India, Volume 07 No. 10, October 2017.
- Priyanka. S. Kotecha (2018): A study on Digital Payment Applications in India, August 2022. Journal of Management Research and Analysis 9(3): 150-156, License .CC BY-NC-SA 4.0.
- Zlatko Bezhovski (2016): The Future of Mobile Payment as Electronic Payment System, European Journal of Business and Management, ISSN 2222-1905 (Paper) ISSN 2222-2838 (Online), Volume 8, NO. 2016.

“BIG DATA PREDICTIVE ANALYTICS FOR E-GOVERNANCE: ANALYSING AND MANAGING DATA THROUGH DATA ANALYTICS”

Ms. Priyanka Sakat
MCM, MCA
priyanka.dsakat@gmail.com
Contact No: 9970260276

Big data is transforming the way governments are using data and information to gain insights and make informed decisions. As it becomes more mainstream, big data analytics can change the landscape of e-Governance projects.

E-Governance refers to providing quality information and government services to citizens and/or other government/non-government organizations effectively and efficiently. Using Big Data Analysis, both service provider i.e., the government and citizens availing services will be benefited. It will help Government in making better decisions and people in getting timely and reliable information. E-Governance Plan in India has the statement and a vision of “Make all Public Services accessible to the common man in his locality, through common service delivery outlets and ensure efficiency, transparency and reliability of such services at affordable costs to realize the basic needs of the common man”. The success of any e-Governance project depends on outcome rather than output in terms of effective delivery of services. Another feature of Big Data Analysis is to determine the outcome.

This paper focuses on role of Big Data analytics in e-Governance projects. Further, it discusses the Big Data Analysis tools and techniques that would be supportive for making better decisions in serving citizens under e-Governance Projects.

Keywords: Big data; data mining; big data analytics; e-Governance

Introduction

Big data is today synonymous with data intelligence, data analytics, data mining, and has widened its scope from reporting and decision support to forecasting, prediction and decision making. Although private businesses organizations are leading the adoption of big data in their operations, governments, across the world, have begun to adopt it in their processes. During the COVID-19 global pandemic, many governments used big data and other supportive data technologies to monitor the spread of dangerous viruses like coronavirus, share real-time information and provide relief to their citizens.

The world is moving towards digitization. In India central and state governments are steadily moving towards digitizing all the government departments, scheme and services. Due to the awareness of people and availability of

network access that emerges, use of E-governance application has increased.

Big data, a term used for the massive amount of digital data collected from various sources, offers new opportunities for innovation, value creation, and decision making to any organization. The definition and scope of big data have evolved from collecting vast amounts of data to the process and technology through which organizations can derive value from their data.

Rapid moving in the technology and the need to respond to the massive changes in the big data create another challenge for the government to make the deal with a huge amount of data easier and to implement effectively multi-channel platforms for digital transformation. The need for technology such as social media, e-participation tools and new models of open data to generate big data also have added to these challenges, in addition to the slow adoption of the public sector and citizens for these new concepts of openness and effective interaction through electronic technology. For citizen's improvements the e-participation processes, government innovations, and citizen satisfaction governments need to enhance the collaboration and engagement. As well, it needs to improve the value that delivers inside and outside of government sectors also satisfies the citizens' demands for better services by collecting data from citizens' activities. When e-government utilizing the big data technologies, which offers a new effective technology to provide interactive services, the e-government will be more than just a big and more than just a data. The term of “Big data” must be used in e-government.

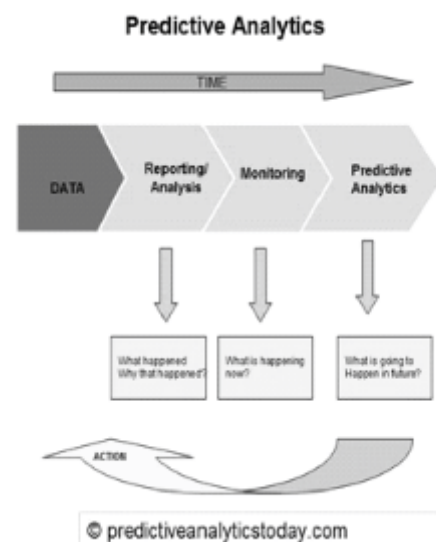

Big data has few key characteristics such as volume, sources, velocity, variety and veracity. The first among these is volume. Experts predict that by 2020, the volume of data in the world will grow to 40 Zettabytes. This affects every business, governments and individual. Based on a recent study, 2.8 Zettabytes of data were created in 2012 and only .5% of that data were used for analysis. Unstructured data, such as texts, notes, logs makes up a large chunk of this data volume and these requires text mining to analyse the data. Business intelligence (BI) provides OLAP based, standard business reports, ad hoc reports on past data. These ad hoc analysis looks at the static past of data. This has its purpose and business uses, but does not meet the needs of a forward-looking business. Forward looking big data analytics requires statistical analysis, statistical forecasting, casual analysis, optimization, predictive modelling and text mining on the large chunk of data available. There are performance issues, when these high volume past data are used in the relational data model, for forward-looking big data analytics, for future in the current system landscape in many organizations.

Benefits of Big Data Analytics in E-Governance

The major benefits of leveraging big data analytics in e-governance projects are:

- Improvement in online information and service delivery by governments for business analytics.
- Bringing transparency in processes
- Monitoring and visualizing performance
- Forecasting citizen demands
- Extracting intelligence and insights for new projects and optimizing existing ones
- Providing better citizen services.

Big Data Applications in E-governance

Big Data in e-governance can be utilized to build several applications. Here are a few ways in which big data can help governments in driving their citizen-centric initiatives.

1. **Policy Planning:** Big data analytics can help policymakers use data from multiple sources to produce economic indicators for policy insights. Big data mining can collect high-frequency and granular data to provide actionable insights into human mobility and economic behaviour. For example, many organizations related to urban planning and public transport are using satellite images, data from vehicle sensors and traffic, video feeds etc., to identify citizen needs, land usage and road construction. Analysis on such data also helps in traffic regulation and movement by providing more time to cross intersections for some roads and lesser times to others.
2. **Law Enforcement:** Law enforcement is a key function of governments. Big data solutions allow law

enforcement agencies to leverage data and information to enforce law, lower crime rates and expand services. New technologies like facial recognition, speech recognition, drones and predictive analytics can be leveraged to strengthen law enforcement and prevent crimes. In Bogota, Colombia, researchers from the World Bank are leveraging big data and risk terrain modelling to understand the relationships between crime and find solutions to it.

Disaster Management

3. : We have already witnessed this happening during the Covid-19 pandemic. Many government organizations used big data analytics to track the spread of viruses and build counter measures. Big data can be used for disaster preparedness and provide relief to the citizens. Higher accuracy in information gathering and weather forecasting can help in alerting citizens of coming natural calamities. It can also be used to identify vulnerable groups like the elderly and children.
4. **Citizen Services:** Citizens are today accustomed to personalized, on-demand and speedy delivery from business organizations and many have similar expectations from government institutions. Government organizations can utilize big data develop innovative delivery channels and improve citizen services. Governments have massive amounts of data and this data can be used to extract administrative insights on various citizen services including education, healthcare, taxes, housing, food distribution, land registration etc.
5. **Fraud Detection:** Most government projects are vulnerable to fraud and other forms of corruption. Big data can help organizations to build robust fraud detection mechanisms. The Australian Electoral Commission (AEC) is using data simulations to investigate electoral fraud. It uses big data to maintain the accuracy, integrity and completeness of electoral data. Big data simulations are used to detect anomalies or frauds. In 2019, the AEC engaged Deakin University to collect data on polling place performance and build simulations to improve polling processes, optimize resource allocation and reduce voting time.

Transaction volume per day in Indian e-Governance projects are growing constantly due to popularity and acceptability of the e-Governance applications among common citizens. This constant growth of e-Governance data size is referring e-Governance projects as a potential candidate for doing BIG data analysis. BIG data

technologies stack enable application stake holders to get faster analytical report from huge amount of historical data, even from unstructured database. Now-a-days, Most of the enterprise drivers have chosen BIG data technology to get the ability for dealing vast amount of data efficiently in order to bring significant business insight, which may lead to take better business decision. In e-Governance, this kind of analytical report could help to Government policy maker to take more corrective decision towards developing Indian society; thus technology could be used for the mankind of Indian Society.



The continuous advancements in the field of ICT and the constant efforts from the Central and State governments have been the foremost forces for the successful launch and reinforcement of e-governance in India. With the help of public and private sectors, governments are encouraging organizations for interoperability to store and process data from a central location that further enhances decision-making. This fastest-growing data is turning into big data. The tools used to study and analyse big data at a great speed and accuracy are known as big data analytics. These big datasets can be text/audio/video/picture, etc. As the use of e-governance datasets is increasing, the citizens expect to analyse and process datasets at greater speed and accuracy.

Strengthening Digital India, e-Governance for Citizens Empowerment

Recognising the value of data as a national resource, the Government of India is harnessing the same to build analytical frameworks and expand its e-Governance initiatives across the length and breadth of the country. Increasing smartphone penetration and data consumption, even in India's hinterland, is enabling the Government to formulate evidence-based policies, better target welfare schemes for the undeserved population, and digitally empower citizens with data-driven inputs.

Earlier in 2017, the Government leveraged big data analytics to launch an ambitious project called “Project Insights” which helped track down tax evaders and flag accounts with sizable black money deposits. Introduction of Goods & Services Tax (GST), one of the biggest reforms in the country's tax structure in decades, is also a shining example of data-driven policy.

Championing the democratic access to all public Government data through a one-stop platform, NITI Aayog's flagship initiative “National Data and Analytics Platform” (NADP) will pave the way for India's data stewardship. Catalysing this further, the Government's push for data localisation and the proposed national regulator, the Non-Personal Data Authority (NPDA), with a mission to "generate economic, social and public value through processing and use of data" will greatly strengthen India's data protection ecosystem.

Applying Big Data Analytics in Governance to Achieve Sustainable Development Goals (SDGs) in India

One of the chief obligations of governance in democratic countries is creating and co-creating value in public service delivery, the process of which is undertaken in a participatory manner so as to ensure an accountable, responsive, and transparent ecosystem (Good Governance, The United Nations Economic and Social Commission for Asia and the Pacific—UNESCAP). To translate these good governance ideologies into practical implementation, it is necessary to ensure the achievement of development targets defined as Sustainable Development Goals such as no poverty, zero hunger, and complete gender equality (SDGs, UNDP, 2015). Further, to achieve these development targets in a sustained manner, converged governance efforts are required at the grassroots, which in turn would inevitably result in the generation of continuous baseline data. This colossal amount of data thus generated at the grassroots when coupled with unstructured citizens' data generated through other digital devices holds immense potential to revolutionize governance processes by providing a foundation for data-backed decision making. Hence, such structured baseline data and unstructured citizens' data must be continuously combined and analysed by application of big data analytics and other emerging ICTs (information and communication technologies).

Conclusion And Future Work

Big data if analysed with good techniques and technologies can give rise to numerous ideas and areas to upon for getting effective results. In the same way if it is been analysed for some services provided by the government to the citizens for better implementation for E-governance plan, will give rise to more effective services. Implementing data analysis with fuzzy sets and statistical method can provide more effective ideas.

11. Bibliography

1. <https://uidai.gov.in>
2. incometaxindiaefiling.gov.in
3. india.gov.in
4. <http://goidirectory.gov.in/index.php>
5. guidelines.gov.in
6. <https://nceg.gov.in/>
7. [https://digitalequality.in/pcmcs-e-Governance initiative-is-a-runaway-success/](https://digitalequality.in/pcmcs-e-Governance-initiative-is-a-runaway-success/)
8. C.L. Philip Chen, Chun-Yang Zhang, "Data-intensive applications, challenges, techniques and technologies: A survey on big data", *informatics Sciences*, published in Elsevier 2014, pp 314-347.
9. "E-Governance transactions in 2013 increased manifolds compared to 2012", <http://www.thinkalytic.com/2014/e-Governance-transactions-in-2013-increased-manifolds-compared-to-2012/>, Jan 2, 2014
10. Alshomrani, Qamar, "Cloud based e-Government: Benefits and Challenges", *IJMSE*, Vol. 4(6), pp. 15-19,2013
11. Chen, Hsieh," Big Data for digital Government: Opportunities, Challenges, and Strategies",*International Journal of Public Administration in the Digital Age*", pp. 1-14,2014
12. Kalbande, Deshpande, Prof. Papat,"Review paper on use of Big data in E-Governance of India", *International Journal for Research in emerging and technology*", Vol. 2, pp.395-402, March, 2015
13. Karthik Kambatta, Giogos Kollias, Vipin Kumar, Ananth Grama,"Trends in big data Analysis", *j.Parallel distributed computer*,pp 2561-2573,2014
14. Chen, Hsieh," Big Data for digital Government: Opportunities, Challenges, and Strategies", *International Journal of Public Administration in the Digital Age*", pp. 1-14,2014
15. Axelsson K, Melin U, Lindgren I (2013) Public e-services for agency efficiency and citizen benefit-findings; From a stakeholder centered analysis. *Gov Inf Quart* 30(1):10–22
16. Bertot JC, Choi H (2013) Big data and e-government: issues, policies, and recommendations. In: *International conference on digital government research*, pp 1–10
17. A.G. Picciano,"The Evolution of Big Data and Learning Analytics in American Higher Education", *Journal of Asynchronous Learning Networks*, pp 9-20,2012
18. Alshomrani, Qamar,"Cloud based e-Government: Benefits and Challenges", *IJMSE*, Vol. 4(6), pp. 15-19,2013
19. Arvind Sathi,"Big Data Analytics: Disruptive Technologies for Changing the Game", 2012
20. Krishna Kumar Verma,Navita Shrivastava,"Exploring role and associated challenges of data mining technique and it's implementation in E- governance", *IJARCT*, Volume 4,Issue 8,pp 3473-3477, August 2015
21. Agnihotri, N., & Sharma, A.K.,"Big Data Analysis and its need for effective E-Governance", *IJIACS*, Volume 4, pp 219-224, March 2015
22. Prasad, Veera Raghav,"Cloud computing technology for effective e- Governance", *IJCSIT*, Volume 3(1), pp. 3241-3244,2012
23. Suh, Vujin, Barac, Radenkovic,"Designing cloud infrastructure for big data in egovernment", *Journal of Universal Excellence*, pp.A26-A38, March 2015
24. Woodside, Amiri, Boldrin,"The impact of ICT and Big Data on e- Government", *Int'l Conf on Advances in Big Data Analytics*,pp. 117-118,2015

LEADING ORGANIZATIONAL DIGITAL TRANSFORMATION USING LOW CODE

Ms. Veena Badgujar

Assistant Professor

Information Technology Shah &
Anchor Kutchhi Engineering College,
University of Mumbai, Mumbai, India.
Email : veena904@gmail.com

Ms. Pranali Vhora

Assistant Professor

Information Technology
Shah & Anchor Kutchhi Engineering College,
University of Mumbai, Mumbai, India
Email : pranalivhora@gmail.com

Abstract

Digital Transformation, uses digital technologies and involves an ongoing, ever-evolving practice that requires a complete change in how a business operates and strategizes itself. It goes beyond just digitizing existing processes and requires a coordinated shift in mindset and action. The journey of digital transformation includes the conversion of knowledge management from tacit to explicit, automation, and robotizing standard operations. Successful digital transformations require a focus on digital-first solutions, optimized processes, and customer-centric mindsets.

This paper traces the importance of organization digital transformation and gives perspective of how Microsoft No Code/Low Code Platform (Power Platform) can help expediting the same. It evaluates various features and how industries can benefit from it.

It summarizes the latest trends and outlook on digital transformation with Low-Code platforms.

Keywords

Digital Transformation, Microsoft Power Platform, style, No Code/Low Code development, PowerApps, Power Automate, PowerBI.

I. Introduction

Digital Transformation, as coined by to Salesforce is the process of using digital technologies to create new or modify existing business processes, culture and customer experiences to meet changing business and market requirements.

It is an ongoing, evolving practice which practically has no end in itself. For organizations to become innovative, efficient, and flexible - embracing the digital transformation, and cultivating the practices in the culture of organization is essential.

It's not just digitizing of organizational existing processes but much more than which requires a coordinated shift, complete change in the mindset and action of how a business operates and strategizes itself. Beginning from the conventional journey of paper based approval for leaves, to hand-written surveys and on field inspections, to converting knowledge

management from tacit to explicit, and even automatic and robotizing the standard operations, Digital transformation means a lot more to the enterprises. The technologies used in the journey includes a combination of AI, automation, cloud solutions, and mobile and desktop applications. Successful digital transformations essentially require a focus on digital first solutions, processes optimized for betterment, and business models that are reimaged by users and leadership without forgetting customer-centric mindset.

II. Importance of Digital Transformation

Day by day, the Digital transformation is no longer remaining optional. Independent on the scale of and nature of organization, it has become to essential part of day to day operations for businesses. For survival, organization needs a competitive and digital-centric strategy.

For betterment of ecosystem, post Covid-19 Pandemic, every organization is initiating some or the other form of digital transformation. This is still a good start, but now they need processes that delivers repeatable success. For every change, organizations might need to go through change management activities, but it's inevitable.

To start with, organizational decision makers need to analyse the teams and skillset of current capabilities along with the digital maturity assessment, this will establish a vision, a starting point for knowing how the robot is critical to your journey. Your Initial steps will bring you to Everest base camp, this is an opportunity gear up with your team and prepare for the climb the white Mountain. It's the beginning of journey, but to conquer the toolset required are the right team, gear and rollback.

The Digital Transformation helps enterprises:

- To improve internal collaboration:
- To boost efficiency:
- Remain market ready and competitive
- Fight situations like Pandemic.

Organizations should quickly adapt their strategies and

embrace fast changing technologies to be first choice amongst competitive in a rapidly changing business environment i.e. follow every latest digital technology trends and seek if it fits to their needs, working towards implementing into business operations as required.

Like in never before situations, the global pandemic forced every industry to adopt digital tools and technologies, at very accelerated speed, just for keeping business survival. Even before the pandemic, many of these technologies were already available, but the stringent situation of Covid-19 gave no choice than adapting them immediately.

III. Approaching Digital Transformation

A. What Organizations can do?

The most essential factor for a successful digital transformation approach, is choosing the right fit technology. Organizations have following choices include:

- I. Readily available, out-of-the-box software that solve each problem.
- II. Having team, or hiring high-code development firm that's surely for high costs may come with slower timelines.
- III. Embracing a right fit development platform designed for scalable digital transformation.

The future of digital transformation looks promising with:

- I. Rapid - No-code/low-code
- II. Maintaining High-performance software
- III. Artificial Intelligence & Machine Learning (AI/ML)
- IV. Blockchain development
- V. Multi-cloud solutions
- VI. Cybersecurity

B. Why to Ebrace No Code/Low Code Platform?

Equipped Enterprise development platforms which also act like plug-play in to other systems helps to conquer the digital transformation complexities and provides a more sustainable approach. Thus, it becomes far better than traditional development system with complex coding.

Such platforms have all the tools, pre-built apps and resources necessary to build new applications and workflows faster. It helps to modernize conventional legacy systems to accelerate the digital transformation.

According to the previously mentioned report*, 70% of individuals who use low-code development platforms were able to learn how to code within a month or less. Additionally, a significant 73% of the participants surveyed stated that they were able to develop applications without the need for coding

within just 3 months.

Adopting digital transformation through low-code or codeless tools requires less time compared to traditional programming, resulting in significant cost savings and increased profits. It allows faster delivery of finished products to the market or internal use to simplify daily operations in departments such as human resources, marketing, logistics, or sales.

Based on experience working with the open-source low-code platform, it has been found that it can reduce the development effort required to create SaaS applications for businesses by up to three times compared to using traditional low-code software. Utilizing a low-code development platform unquestionably reduces the time needed to deliver digital solutions and is also effortless.

IV. VARIOUS NO-CODE / LOW-CODE PLATFORMS

Listing the options in this space of Low Code/No Code development platform for Organizations, following are leading providers.

As per Gartner Research, leaders in this space are: Microsoft Power Apps, Siemens Mendix, Appian, OutSystems, ServiceNow, Salesforce Lightning etc.



Image 1: Magic Quadrant for Enterprise Low-Code Application Platforms (Source: Gartner)

From the options, Microsoft No Code /Low Code platform i.e., Power Platform can be seen as the promising, sustainable, platform given in the light of most of the Organizations are already using multiple Microsoft stack product for day to day need. Microsoft

Power Platform application easily fit in the MS ecosystem.

V. MICROSOFT LOW CODE/NO CODE PLATFORM

By definition, the Microsoft Power Platform is a set of business applications helping organizations transform the way employees work. It includes Power BI, Power Automate, Power Apps, Power Virtual Agents, and Power Pages in its primary stack. These applications can be individually used, or can be connected to each other and to other Microsoft and external apps for managing complete business requirement. Users are enabled to analyse data, build apps, automate processes, and create virtual agents themselves or with little skill-up/training.



Image 2: Microsoft Power Platform Blog (Source: Microsoft CloudBlogs)

The Power Fx is a low-code programming language for the Power Platform

A. Components of MS Low Code Platform

- Power Apps: Turn ideas into organisational solutions by enabling everyone to build custom apps that solve business challenges.
- Power Automate: Boost business productivity to get more done by giving everyone the ability to automate organisational processes.
- Power BI: Make informed, confident business decisions by putting data-driven insights into everyone's hands.
- Power Virtual Agents: Easily build chatbots to engage conversationally with your customers and employees—no coding required.
- Power Pages: Quickly build low-code business websites for delivering vital information and services to your customers.

B. Features of Power Platform

Following are the key features that traces strong usefulness of the platform:

- Low-code solutions with drag-and-drop features

and easy collaboration.

- A visual interface for creating and designing the user interface (UI) of the application.
- AI services enabling users to create apps by processing natural language.
- Numerous data sources in combination of thousands of connectors
- A library of pre-built components that can be used to build various features and functionality.
- Easy implementation and seamless integration with Microsoft technologies and related apps
- Workflow tools for automating business processes and creating approvals and other processes.
- Deployment and management tools for publishing and updating the application.

In a nutshell – the benefits of MS Low Code Platform include but not limited to:

- Accelerate app development: With low-code, organizations can develop and test apps up to 90% faster, enabling rapid experimentation with new ideas and business models.
- Foster collaboration and engagement: Low code promotes alignment between business and IT and encourages citizen development, empowering employees to participate in app development.
- Use user-friendly visual tools: Low-code provides intuitive visual modelling tools with drag-and-drop and WYSIWYG interfaces, making app development accessible to a wider audience.
- Leverage out-of-the-box functionality: Low-code platforms offer pre-built components and templates for various tasks, reducing the need for custom coding and accelerating time to value.
- Reuse app components and scale easily: Low code allows for the reuse of app components, simplifying maintenance and maximizing scalability across different platforms and devices.
- Ensure security and governance: Low code provides enhanced architectural security and supports easy reporting and monitoring, ensuring compliance with industry and regulatory standards.
- Manage the app lifecycle: Low-code platforms offer complete application lifecycle management, from design and development to testing, deployment, and maintenance.
- Lower the entry threshold for digitization: Low-code and no-code platforms democratize app development, enabling non-technical users to participate in digitization efforts and reducing the need for specialized programming skills.

In addition, low-code and no-code technology offer an intuitive interface with drag-and-drop functionality and many ready-made components that help users

create solutions to support rapid application development, growth, and business scaling without the involvement of the IT department.

VI. POWER PLATFORM AS BUSINESS ENABLER

Microsoft Power platform can help enterprises conquer challenges associated with digital transformation.

Agility and Speed

Businesses often face a significant hurdle in initiating new projects due to the lengthy development cycle and complex infrastructure architecture. However, low-code platforms provide a solution by abstracting functionality and presenting a model-driven visual environment that accelerates application development. These platforms come equipped with pre-built templates that expedite experimentation and facilitate the integration of feedback, thereby accelerating the execution of "product-to-market fit." By leveraging low-code platforms, businesses can bring new offerings to the market expeditiously and adapt to application changes without disrupting their operations. This capability extends from hard-core professional development to citizen development, contingent on the appropriate platform.

Application Portfolio Rationalization

To streamline their application portfolio, enterprises can benefit from utilizing a low-code platform instead of deploying multiple solutions. A reliable low-code platform offers various capabilities like workflows, content management, mobile app development, collaboration, business rules, RPA, AI/ML, and more. By utilizing a standardized low-code modelling environment, enterprises can address data, process, and security vulnerabilities, promoting IT governance.

Solve the Build v/s Buy Puzzle

A low-code platform offers a solution that enables businesses to achieve the best of both worlds by allowing them to develop custom applications without starting from scratch. By providing powerful out-of-the-box features, a low-code platform can jumpstart digital transformation efforts, making it easier for businesses to develop custom applications while avoiding the limitations of traditional application development and common business applications.

Continuous Integration/Continuous Delivery (CI/CD)

A low-code platform offers businesses the ability to develop applications quickly and make changes with ease, thanks to a visual paradigm for application development and a robust version control and

traceability system.

Low-code platforms require minimal coding, which leads to faster development, greater experimentation, rapid innovation, and rapid deployment. They also support faster integration with internal legacy and external systems, enabling real-time business insights for quick decision-making. Additionally, low development costs allow organizations to experiment without exceeding their budget.

Thus, in a nutshell organization's approach should be: Skill-Up, Build, Operate and Scale-Up.

VII. REAL WORD APPLICATION FOR DIGITAL TRANSFORMATION USING POWER PLATFORM:

There are various real-world applications that have already transformed businesses using Microsoft power apps:

- A field Operations Inspection staff needs to schedule survey process.
- Field Engineer performing fulfilment processes. Link customer data to specific digital marketing platforms
- Create Approval mechanisms for Purchase Order submission or client document submission.
- Internal chatbot which provides quick answers for specific industrial calculations.

Additional strategic examples involve developing applications that integrate with ERP, CRM, HR, and IT systems, reducing the necessity for entering data into multiple systems.

Here are some more examples of real-world digital transformation that have been achieved using Microsoft Power Platform:

An agriculture company in the US boosted its efficiency using Power Apps by creating a mobile app that enabled their workers to track their daily tasks like watering plants and harvesting crops. The app enhanced communication minimized errors and increased efficiency.

A healthcare provider in Europe used Power Automate to automate their workflows for patient appointment scheduling, medication management, and patient communication. This resulted in better patient care, increased efficiency, and cost savings.

An energy company in Australia digitized their processes for managing and maintaining their power stations using Power Platform. They used Power Apps

to create a mobile app for data collection and analysis, and Power BI for real-time reporting and analytics. As a result, they achieved improved efficiency, reduced downtime, and cost savings.

A manufacturing company in the US automated their workflows for inventory management, purchase order processing, and quality control using Power Automate. This brought about increased efficiency, improved accuracy, and reduced costs.

A financial services company in Asia used Power Platform to create a customer portal for their clients to access their accounts, conduct transactions, and view their investment portfolios. This led to better customer experience, increased engagement, and reduced call centre volume.

These are just a few examples of how Microsoft Power Platform has been used to drive digital transformation and deliver better business outcomes.

The Low-Code platform by Microsoft aims to increase efficiency and productivity in businesses by automating processes and digitizing operations. This low-code solution empowers users to build their own applications without needing the assistance of IT professionals or experts.

VIII TRENDS IN NO CODE/LOW CODE

The rise in popularity of low-code tools has led organizations to explore new ways to maximize their benefits. Here are four current trends in low-code app development that can accelerate digital transformation efforts:

Trend 1: Automations/Workflows

Repetitive manual processes can be replaced with Power Automate process flows, freeing up time and resources for more innovative and business-critical tasks.

Trend 2: AI-Enabled Apps

Adding intelligence to apps using Power Virtual Agents and Power Automate can save even more time. For instance, an app that captures business card data can automatically process text and enter it into the correct fields in the sales tool, streamlining the process.

Trend 3: Custom Code to Extend Apps

Low-code platforms often come with pre-built apps and workflows that can be easily modified with custom code to create powerful solutions in a fraction of the time it would take to develop from scratch. IT teams

can use low-code platforms to gain a significant head start on custom solutions as part of their organization's digital transformation strategy.

Trend 4: Improving Existing Solutions

Low-code APIs offer a fast and simple way to connect devices, data, and other apps with existing platforms to enhance functionality. This is particularly useful when existing systems cannot be fully replaced at the start of digital transformation, and organizations want to enhance their capabilities.

IX. THE FUTURE OF LOW-CODE AND DIGITAL TRANSFORMATION

Organizations from various industries are actively seeking ways to meet challenges and improve business performance through digital transformation. The introduction of low-code and no-code tools allows businesses to take more risks and experiment with their ideas, resulting in digital innovation.

Organizations are already utilizing low-code technology to gain a competitive edge by enhancing business agility and productivity. Low-code platforms are also assisting IT teams in teaming up with various departments.

Low-code has proven to be a valuable solution for enterprises that face challenges in accessing relevant resources to meet their business needs. With low-code, businesses can quickly develop and launch digital products, thereby accelerating their time-to-market and enabling them to respond to market dynamics faster. This technology also improves efficiency by reducing the time and resources required for development, testing, and deployment, ultimately resulting in cost savings.

It is recommended that every organization should adopt a low-code platform to take advantage of the opportunities it provides for accelerating productivity and achieving faster results with apps and tools.

"The future of coding is no coding at all." - Chris Wanstrath, CEO of GitHub.

By embracing digital transformation and adopting low-code platforms, companies can expect to see benefits such as increased revenue growth, higher customer loyalty, and a competitive edge. Failing to keep up with modern digital technology can put a company at a disadvantage, especially in terms of delivering a satisfying customer experience.

Therefore, it is important to take action and start transforming your organization today using Microsoft Power Platform.

REFERENCES

- [1] Zhaohang Yan “The Impacts of Low/No-Code Development on Digital Transformation and Software Development” University of Toronto Toronto, Canada. (references)
- [2] Sakir Yucel, Wexford “Modeling Digital Transformation Strategy”, International Conference on Computational Science and Computational Intelligence (CSCI), 978-1-7281-1360-9/18/\$31.00 ©2018 IEEE
- [3] Ž. Dobrović, "The Role of Business Processes in Digital Transformation of the Organization," 2021 44th International Convention on Information, Communication and Electronic Technology (MIPRO), Opatija, Croatia, 2021, pp. 1329-1334, doi: 10.23919/MIPRO52101.2021.9596754.
- [4] Z. Štaka, M. Vuković and V. Vujović, "The Role of Digital Competencies in the Process of Digital Transformation," 2022 21st International Symposium INFOTEH-JAHORINA (INFOTEH), East Sarajevo, Bosnia and Herzegovina, 2022, pp. 1-6, doi: 10.1109/INFOTEH53737.2022.9751285.
- [5] Business Application Platform <https://powerplatform.microsoft.com/en-in/>
- [6] Overcome the Challenges of Digital Transformation with Vision Setting | Mendix
- [7] Microsoft Power Platform documentation - Power Platform | Microsoft Learn Microsoft Learn
- [8] Microsoft Cloud Blogs



EMPIRICAL EXPOSITION MODEL TO ANALYZE SUICIDE CAUSES IN INDIA

Dr. Poonam Sawant

Asst. Professor, Sinhgad Inst. of mgmt.
& Comp. Application, Pune, India
Poonam25m@gmail.com

Prof. Yogesh Sharma

Asst. Professor, Sinhgad Inst. of Mgmt.
& Comp. Application, Pune, India
yogeshsharma@sinhgad.edu

Prof. Navnath Choudhari

3Asst. Professor, Sinhgad Inst. of Mgmt.
& Comp. Application, Pune, India
navanathchoudhari_simca@sinhgad.edu

Mr. Mihir Limje

4Student, Sinhgad Inst. of Mgmt.
& Comp. Application, Pune, India
mihirlimje867@gmail.com

Abstract:

Suicide is an emerging and serious public health issue now a days. It has been extensive and affecting people's mental as well as physical health. This impacts not only on an older person but on youngest crowd too. People believe in suicide as a last option to tackle their uncontrollable and stressful situations. About 8, 00,000 people die by suicide worldwide every year in the world and maximum out of them are Indians. According to WHO, India's average annual suicide rate is 10.5 per 1 lac which is extreme as compared to suicide rate of world which is 11.6 per 1 lac. Day by day the rate is increasing. Therefore, finding out the root causes behind the suicides is a responsible job to control the suicide rate in INDIA and for that various techniques and methods can be used.

The main aim of this research is to develop an empirical exposition model using data science techniques to analyze the suicide database and explore the causes behind it. In this research we have analyzed various patterns and causes of committing suicide. To fulfil the aim researchers have collected relevant information from various sources and applied advanced data science techniques. At the end researcher implemented the model to bring out some conclusions and effective solutions.

Keywords:

Empirical, Exposition, Suicide, Prevention, Data science.

I. INTRODUCTION

Suicide is one of the top three causes of death in the world. Suicide rates in India has been increasing terrifically over the past five decades. The rate of suicide continuously increased from 2001 to 2019. Suicides during 2019 increased by 3.4% in comparison to 2018. In India women suicide deaths increases 25.3% to 36.6% and men suicide deaths increases from 18.7% to 24.3% from 1990 to 2016 as compare to global suicide deaths. In 2019, highest number of suicide deaths were recorded in Maharashtra followed by Tamil Nadu, West Bengal, Madhya Pradesh, and then Karnataka. Family problem is the most common cause and in some cases, we can't even find the causes of suicide. [2]

As per the study people of 15 – 29 age group attempted more suicide as compared to those below 15 yrs. and above 59 yrs. In 2020 over 153000 deaths were recorded due to suicides. Suicides and suicide attempts of anyone badly impacts on others mental and physical health including

families, friends, colleagues, communities and society. Suicides are preventable and it can be done at individual, community and national levels by identifying the causes and creating the awareness [1][2].

To prevent suicide attempts, identification of suicide causes is a significant task and responsibility of each and every individual. Purpose of this study is to learn different patterns of suicides and its changing rates using various data science techniques to identify and understand the major and minor causes. This study has empirical as well as theoretical importance to create awareness about suicide activities which will be helpful for government, NGO's and society to take an initiative to prevent and control suicide rate.

II. RELATED WORK

According to the World Health Organization Geneva, as the years pass suicide rate in India increases. India is one of the biggest contributors of suicide activities as shown in figure 1. Majority of the people commit suicide without planning. Family problems, illness, Drug abuse/alcohol addiction, marriage related issues, love affair, bankruptcy/indebtedness, failure in examination, unemployment, professional/career problems, property dispute, death of dear person, suspected/illicit relation, fall in social reputation, impotency/infertility and some unknown factors are the common causes of suicide. There was an increase of 18.2% deaths due to forces of nature and increase of 2.0% deaths due to other causes during 2019 as compared to 2018[1][5].



Fig.1: Suicide Activities Rate

[Source: <https://en.wikipedia.org>]

According to National Crime Records Bureau (NCRB), suicides in India rose 10% from 2019 to an all-time high of 1, 53, 052 in the pandemic year of 2020.

- The maximum cases recorded in Maharashtra which is worst among states with 4,006 deaths including a 15%

- increase in farm worker suicides.
- Poverty and unemployment registered the biggest increase following by drug abuse or alcohol addiction, illness, and family problems.
- Students have registered an increase in deaths by suicide it was likely related to relatively longer-term prospects perhaps inability to continue education than exams [8].
- Another reason observed for committing suicide is ragging. More than 20 students commit suicide as a result of ragging every year. According to representatives of the National Anti-Ragging Helpline Most of the cases observed in medical colleges [6].

Higher literacy, higher socioeconomic status and higher expectations are the possible causes of the increasing suicide rates in the southern states in early years [3]. As per the serological verbal autopsy studies in rural Tamil Nadu, the annual suicide rate is 6 to 9 times the official rate [4]. In future there is no visible significant relief for suicide deaths in India. Wide exploration of sample cases and root cause analysis may provide important information for suicide prevention [7][8].

III. OBJECTIVES OF THE STUDY

- To study and analyses the suicidal rates and causes in India.

IV. METHODOLOGY

There has been noticeable increase in the rates of suicide cases due to various reason in India over the many years. Though trends of both increases and decrease in suicide rates have been cleared Covid-19 also impacted people's thoughts negatively. Therefore, in this section, we have analyzed the Increasing suicide rate and there causes in INDIA following below steps.

- Suicide Data Collection.
- Data Preprocessing (Data Selection, Data Cleaning, and Data Transformation) using Python.
- Rules Generation and Pattern Discovery
- Dividing the data into a different table.
- Adding a current into the existing dataset.
- Statistical Data Analysis and Interpretation
- Visualization using Matplotlib, Seaborn and PowerBI

Dataset of suicide contains various parameters suggested by NCRB including Causes, Education status, Means adopted, Professional profile, and Social status etc., as shown in Table 1 with different type of content. Python tool is used for data analysis.

Fields	Values
States	{States in INDIA}
Years	{2001-2012} {2013-2019}
Type code(Category)	Causes, Means adopted, Professional profile, Education Profile, Social Status
Type	{Category types}
Gender	Male, Female
Age group	0-100+
Total	{Total No. of Suicide}

Table 1: Dataset

Above parameters are used for further analysis which is carried out in section V for finding out root causes of the suicides.

V. DATA ANALYSIS AND INTERPRETATION

Types of causes:

Following types of causes available in the dataset:

Causes Not known	3332
Other Causes (Please Specity)	3065
Family Problems	3013
Other Prolonged Illness	2680
Insanity/Mental Illness	2572
Love Affairs	1697
Poverty	1568
Dear Person Death of	1511
Fall in Social Reputation	1496
Suspected/Illicit Relation	1420
Drug Abuse/Addiction	1406
Unemployment	1404
Property Dispute	1393
Failure in Examination	1379
Bankruptcy or Sudden change in Economic	1373
Cancer	1233
Professional/Career Problem	1160
Cancellation/Non-Settlement of Marriage	1116
Paralysis	1105
Not having Childrens	1039
Illness (Aids/STD)	1011
Dowry Dispute	871
Divorce	847
Physical Abuse (Rape/Incest Etc.)	731
Ideological Causes/Hero Worshipping	471
Illegitimate Pregnancy	420
Bankruptcy or Sudden change in Economic Status	126
Not having Children (Barrenness/Impotency	92

Table 1 : types of causes

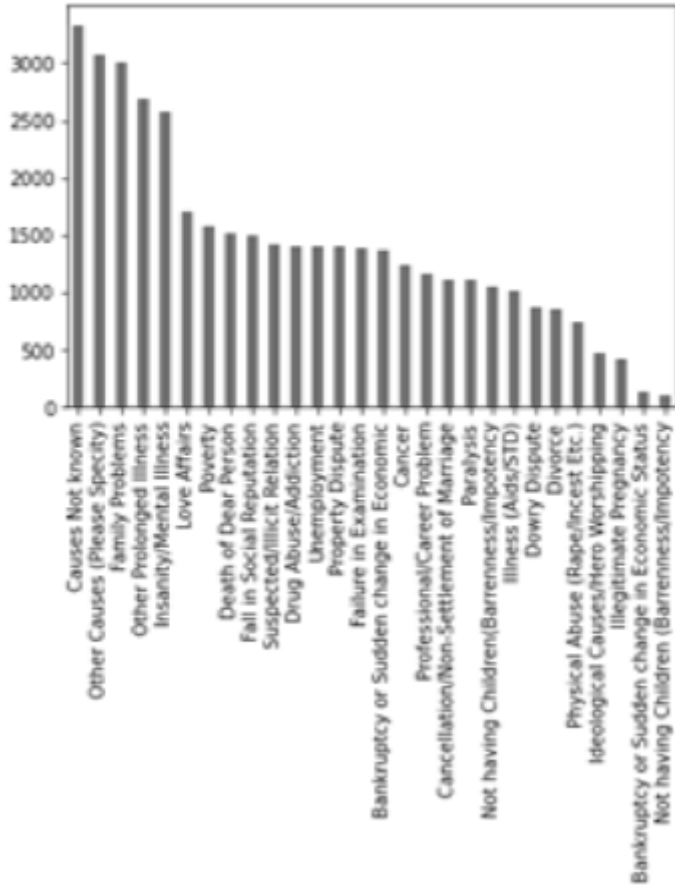

Fig 1 : Type of Causes

From Figure 1 and Table 1 it has been observed that, mostly the cause Family Problems in committing suicide is more, whereas not having Children and bankruptcy committing suicide is less.

2. Means Adopted

By Hanging	3514
By Consuming Other Poison	2952
By Drowning	2609
By Consuming Insecticides	2608
By Fire/Self Immolation	2582
By Other means (please specify)	2415
By coming under running vehicles/trains	1782
By touching electric wires	1483
By Jumping from (Other sites)	1384
By Jumping from (Building)	1325
By Overdose of sleeping pills	1272
By Fire-Arms	1236
By Over Alcoholism	1228
By Jumping off Moving Vehicles/Trains	1137
By Self Infliction of injury	1093
By Machine	504
By Other means	213

Table 2 : types of mean adopted



Fig 2: Plot of types of mean adopted

From Figure 2 and Table.2 It has been observed that by hanging and consuming poison of count in committing suicide is more, whereas by machine and self-infliction of injury committing suicide is less.

3. Professional Profile

Others (Please Specify)	5509
Unemployed	2424
Farming/Agriculture Activity	2310
Service (Private)	2230
Student	1854
Self-employed (Business activity)	1793
Service (Government)	1771
House Wife	1543
Professional Activity	1513
Public Sector Undertaking	1506
Retired Person	838

Table 3: Type of Professional Profile



Fig 3. Plot of types of professional profile

From Figure 3 and Table 3 we can interpret that the rate of unemployed and farming person committing suicide is more than retired persons

4. Education Status

Middle	811
Primary	803
Matriculate/Secondary	803
No Education	773
Hr. Secondary/Intermediate/Pre-Universit	733
Graduate	643
Diploma	529
Post Graduate and Above	507

Table 4: Type of Education Status

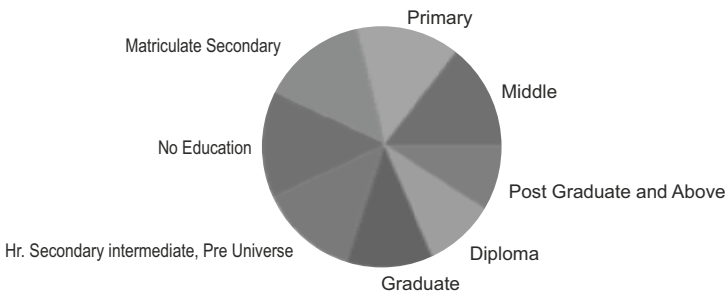

Fig 4: Plot of types of education status

From Figure 4 and Table 4 we can interpret that the Primary and middle educated person committing suicide maximally, whereas post graduated and above educated person committing suicide is less.

5. Social Status

Middle	811
Married	824
Never Married	813
Widowed/Widower	626
Separated	566
Divorcee	520

Table 5: Type of Social Status

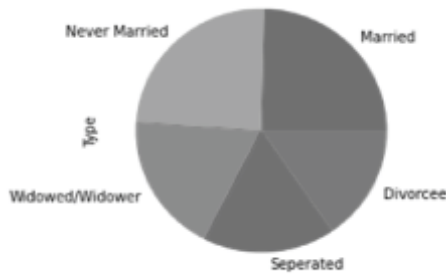

Fig 5: Plot of Types of Social Status

From Figure 5 and Table 5 it has been concluded that the count of married and unmarried person in committing suicide is equal, there is no much difference between them.

Gender wise, age wise and state wise analysis is also done as shown in figure 6 to 9.

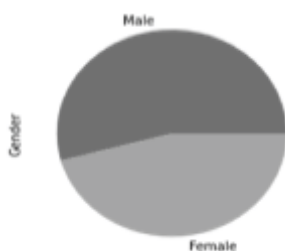

Fig. 6 : Male female Ratio.

From Figure 6, we can understand that, percentage of suicide is 55% in male, whereas in female, it is 45%. It indicates that, Male gender have more depression levels compared to female gender.

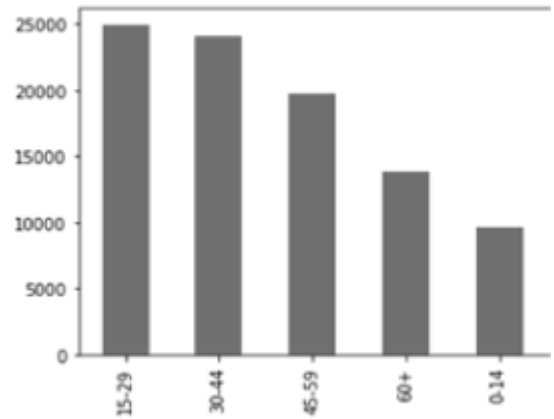

Fig. 7 : Age Group with Count.

Figure 7 represents different age groups. The ratio of committing suicide is more in 15-29 and 30-44 age group.

Figure 8 represents year wise total number of suicides based on different age group for better understanding whereas figure 9 represents the year wise plot (2001-2022) and causes for committing suicides.

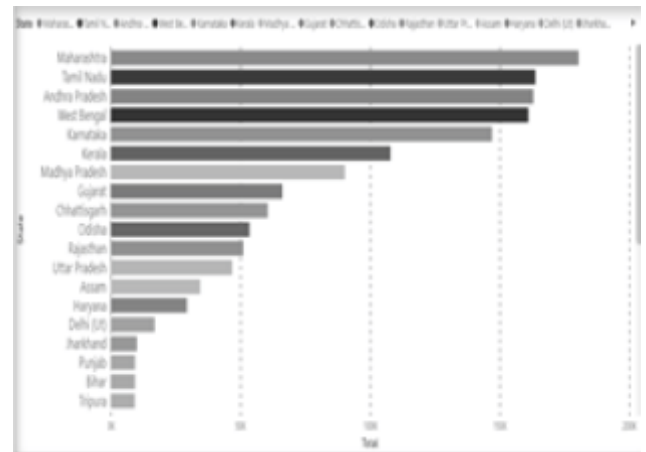

Fig 8 : State Wise Total Number of Suicides Year Wise

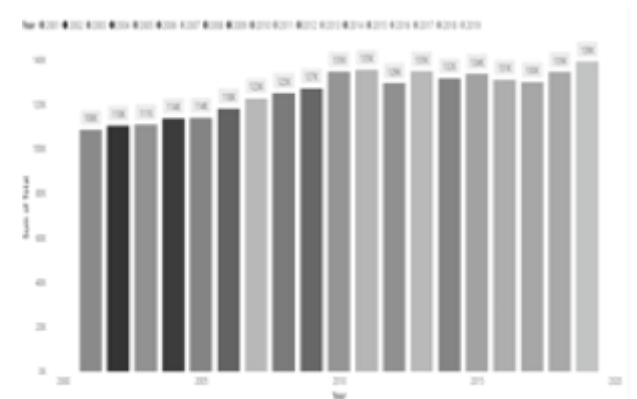

Fig 9 : Total Number of Suicides Year Wise (2001-2022)

I. CONCLUSION

This paper defines the empirical exposition model for Analysis of the continuously increasing suicide rate in INDIA. The dataset used is provided by NCRB (National Crime Records Bureau) and analyzed using python along with the visualization libraries. Based on the results it has been observed that the suicide rate is continuously increasing from 2001 to 2022. Family problems, Education status, Means adopted, Professional profile, and Social status are the main root causes for the suicide attempts. Most of the suicides occur due to family problems and it is surprising to notice from 2006 it is gradually increasing and by 2012 it has reached to 35000 cases as per the dataset considered.

According to study in India in every hour approximately 15 and per day approx. 371 suicide cases are registered. The main reasons encountered are instability in thinking and lack of motivation. Medical care claims that "person who attempts suicide shall be presumed to be suffering from mental illness at that time". In India, addressing this issue, a Mental Health care Bill got introduced in 2013 towards decriminalizing suicides. As per the records collected from 2001-2019, mostly students and farmers are vulnerable to suicides.

Suicide is preventable and requires different awareness strategies at all levels of society.

II. REFERENCES

- [1] https://en.wikipedia.org/wiki/Suicide_in_India
- [2] https://www.who.int/health-topics/suicide#tab=tab_1.
- [3] Vijayakumar L. Altruistic suicide in India. Arch Suicide Res. 2004;8:73–80. [PubMed]
- [4] Accidental Deaths and suicides in India. National Crime Records Bureau. Ministry of home affairs. Government of India. 2007 [Google Scholar]
- [5] Accidental Deaths & Suicides in India - 2019 | National Crime Records Bureau". ncrb.gov.in. Retrieved 22 September 2021.
- [6] Deepika, K. c (6 August 2015). "Ragging leads to 15 suicides in 18 months". The Hindu. ISSN 0971-751X. Retrieved 13 October 2020.
- [7] Swain, Prafulla Kumar; Tripathy, Manas Ranjan; Priyadarshini, Subhadra; Acharya, Subhendu Kumar (29 July 2021). "Forecasting suicide rates in India: An empirical exposition". PLOS ONE. 16 (7): e0255342. Bibcode:2021PLoSO..1655342S. doi:10.1371/journal.pone.0255342. ISSN 1932- 6203. PMC 8321128. PMID 34324554.
- [8] <https://www.drishtias.com/daily-news-analysis/accidental-deaths-suicides-in-india-report-2020-n>

IMPACT OF COMMUNICATION ON INTERNATIONAL BUSINESS: THE CASE OF BUENOS AIRES CASE

DR PRADEEP KUMAR

University of Applied Sciences in Nysa, Poland

E-mail: pradeep.kumar@pans.nysa.pl

ABSTRACT

Effective communication is directly proportional to effective negotiation which is applied to the skills of an enabler's personality, adaptability, and knowledge of the multicultural and multilingual practices. It opens the door for better discussion among individuals, industries, and nations to reach an alternative that would satisfy all the participating actors. Especially in today's world when the global business cycle has changed from national to international practices based on- recovery (= uprising), growth (= expansion/boom), recession (= contraction/downturn), depression (= slump), and the role of communication is likely to increase. When businesses are organized based on strategies and planings, they can be structured that suit their best objectives by function, product, customer type, and geographical areas. Their working conditions, product quality, and services offered to the customers create their brand value in the specific market. Their strategies and planning are defined for the longer-term process as the company's mission that determines the overall goals of an organization, and allocating resources to reach those goals by the top and middle managers, while operational planning is concerned with translating the general, long-term goals into more specific concrete objectives which is monitored by day-to-day work of departments by middle and supervisory managers. Each level of structure and planning of a company determines the success of that company. It is only possible to maximize the growth of a company by minimizing the gap of communication between the top-level managers to supervisory level managers, and from the management board to a general low-level worker. It has to be believed that the better the communication is the better working working condition would be.

Keywords:

communication, impact, international business, negotiation, moderator

1. Introduction

This research paper is inspired by the case studies conducted at the Department of International Business, Faculty of International Relations, Prague University of Economics and Business, Prague, Czech Republic. An international student business competition was organized on November 6-7, 2023. The very first edition of such kind of competition took

place where students and experts were invited to work together on mysterious business cases from around the globe without disclosing the cases before the competition. A total of 27 students were registered with 14 nationalities. Five international professors /experts were also invited to be supervisors for the student groups and trained them for the competition.

Day one on the 6th of November 2023, all participants were welcomed by the organizer Prof. Vít Hinčica, at the Department of International Business, and introduced to the competition. The cases were prepared for the Department of International Business, Prague University of Economics and Business based on the Author's imagination or fiction. Later five separate groups of students were drowned with the assignment of mysterious cases. Each group was assigned one supervisor to train them for the next day of the final competition. Some students worked almost overnight to find the right solution to their cases. The group was truly international with multi- language and multi-cultural practices. Now the challenges we had to unite the group and let them understand the case in a most simple language to make their clear concept of the case and assign them their roles as characters of the case. As the case was full of friction it inspired us to find the best solutions working for an international business environment "The Buenos Aires Case"

The entire team was dedicated and well-motivated to find the right solution for the assigned case. On the 2nd day before the competition, the entire team practiced well under the guidance and supervision of their supervisor. Every team member was assigned a role to deal with the possible best solutions for the negotiation and communication tools. The time came when they had to present the case. The entire team did well with an extraordinary performance. And finally, the team supervised by the Author, was declared the winner of the competition. The best-performing students from the non-winning groups were also announced.

The practices of multicultural and multilingual skills became an identical tool of communication under this research paper which gives the best outcome of the competition. Similar tools have been used to solve mysterious business cases, applicable to an international environment.

Assistant Professor Vít Hinčica, Department of International Business, Faculty of International

Relations, Prague University of Economics and Business, Czech Republic. An author of Competition and Mysterious Cases.

The author of this research paper, Dr Pradeep Kumar, University of Applied Sciences, Nysa, Poland. Therefore it was necessary to conduct thorough research on the topic “Impact of Communication on International Business” by involving learners, experts from academics, scientists, policy-makers, representatives of companies, government agencies, politicians, and others and provide the best solutions that can be useful for the development of communication skills and global businesses.

2. Aim of this Research Paper

The main aim of the study is to identify weaknesses, assess risks, and recommend coordinated solutions for effective communication to find the best solutions in any mysterious cases. This research will contribute to future work, explaining how effective communication skills can find the best solutions for all involved parties in all kinds of cases.

The presented case “The Buenos Aires Case” was created and presented at the Department of International Business, Faculty of International Relations, Prague University of Economics and Business during an international student business competition organized and conducted on 6-7 November 2023 at Prague, Czech Republic, where the author was assigned with students to find the solution for the case as a supervisor, and his team is the winner of the competition, it is worth taking the final opinion and published it as a research paper which will be beneficial for other students and experts.

The set of questionnaires was drafted and shared with the above-mentioned groups. The survey also allowed all the participants who took part in this competition “International Student Business Competition” in Prague, Czech Republic as well as non-participants of the case and regular students of the author at the faculty of Modern Languages, University of Applied Sciences in Nysa, Poland, and others. The questionnaire comprises five theses on the shaping of phenomena in the studied area as well as enablers and barriers to their implementation.

3. Hypothesis of the Research Papers

The entire research paper is based on five hypotheses:

1. Communication is always developed as a tool to find the best solutions for any ongoing conflict for a specific objective to be achieved.
2. The buyer might had the wrong intention to order and not declare receiving the goods sent by the seller.
3. The Sellers might had the wrong intention to get

the order and not dispatch the same goods.

4. In the Buenos Aires Case, communication was the issue that dealt with the internal interest and degrading the company's image.
5. Communication is the ultimate goal to find business solutions based on knowledge and methods applied by the mentors to create a friendly environment based on give and take/receiving and delivering methods.

4. The Outcome of the Research

Hypothesis 1. Communication is always developed as a tool to find the best solutions for any ongoing conflict for a specific objective to be achieved. It has been approved by the participants in this research work. The questions were asked, how do you assess the significance of the thesis for achieving a concrete goal as an objective, out of ongoing conflicting issues?

Figure 1. Respondent has selected the most effective communication tools as the ultimate tool.

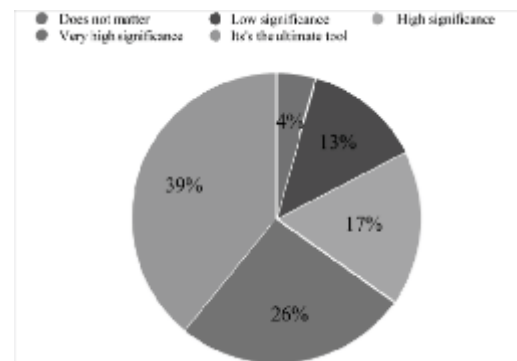

In Figure 1. It was noticed that 39% of the respondents believe that communication is the ultimate tool for conflict resolution mechanisms. None of them agreed that it does not matter, and only 4% believe that it has low significance.

Figure 2. How in your opinion, the thesis will be effective even in the Buenos Aires Case?

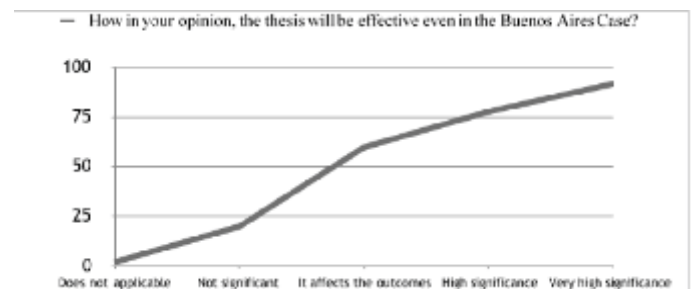

Even though the Buenos Aires Case was based on friction it is very much applicable to all the cases related to national and internal corporate environments. Research shows that deal-making

across cultures tends to lead to worse outcomes as compared with dealing with the same corporate cultural practices. A total of 92% of the respondents believe that the thesis 'Communication is always developed as a tool to find the best solutions for any ongoing conflict for a specific objective to be achieved' has very high significance on mysterious cases while only 2% believe that it does not matter.

Figure 3. What is the impact of the following enablers on the implementation of the thesis?

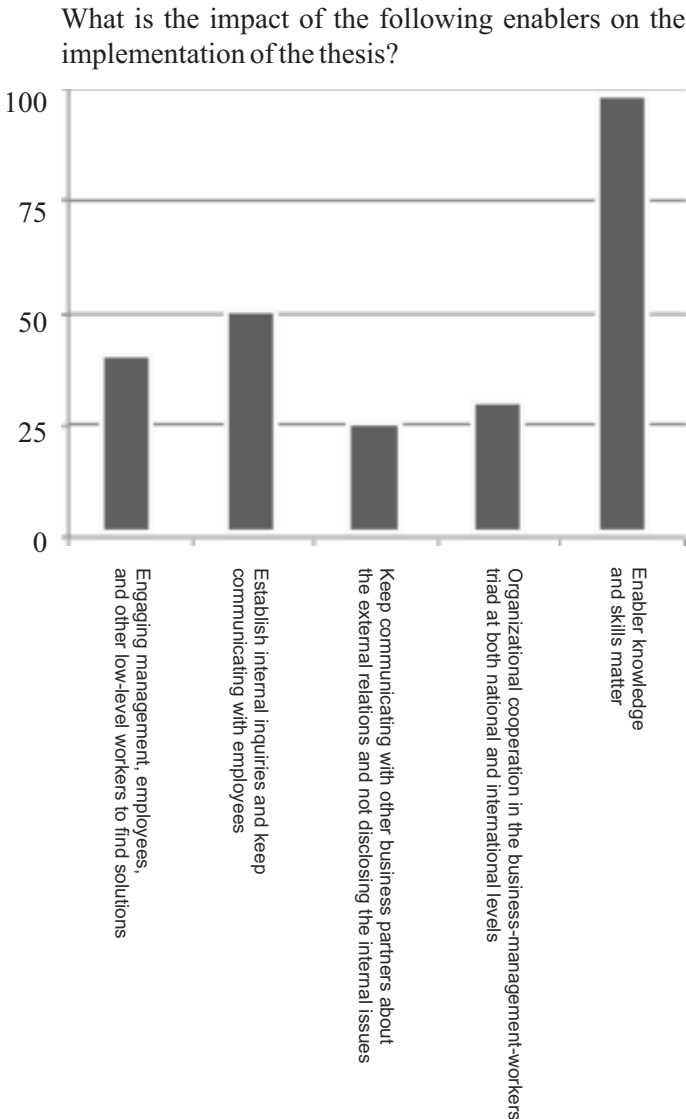

According to Figure 3, research data shows that the role of the enabler is very important for successful communication. As we discussed communication is an intense process involving the exchange of messages. These messages are not necessarily bits and pieces of information but should be given and taken. What needs to be shared with others during the process of communication Insufficient competencies of employees regarding communication skills for settling the conflict Low level of technological

advancement for tracing the order, and goods before the clearance would be a complex mix of ideas, attitudes, emotions, intercultural experiences, and having a good command over language. More than 98% of the respondent expressed their views about the role of the enabler's importance is very high. For any successful communication in complex issues or mysterious cases, it is the enabler's skills and personality who succeed the negotiation successfully and establish fruitful communication.

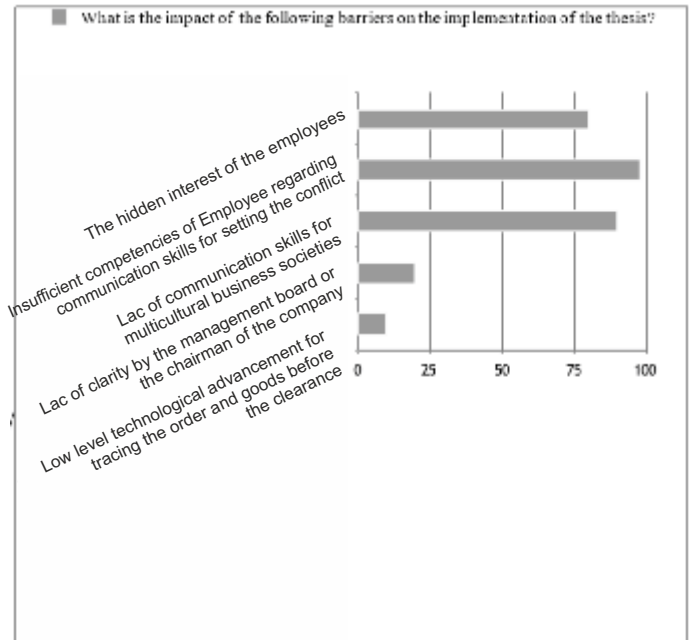

Figure 4. What is the impact of the following barriers on the implementation of the thesis?

The research presented in Figure 4 is very significant which explains that 98% of the respondents agreed with the statement that 'insufficient competencies of employees regarding communication skills for settling the conflict' is one the strongest barriers to solving the mysterious cases. communication in multicultural environments. While more than 90% of the respondent believes that a 'lack of communication skills for multicultural, and multilingual business societies' is the other largest barrier to a successful negotiation with effective communication. And even less than 10% believe that 'low level of technological advancement for tracing the order, and goods before the clearance'.

Figure 5. Determine the extent to which the thesis statement will affect the following actors, where 1 indicates that the impact of the thesis is very low, and 7 that it is very high.

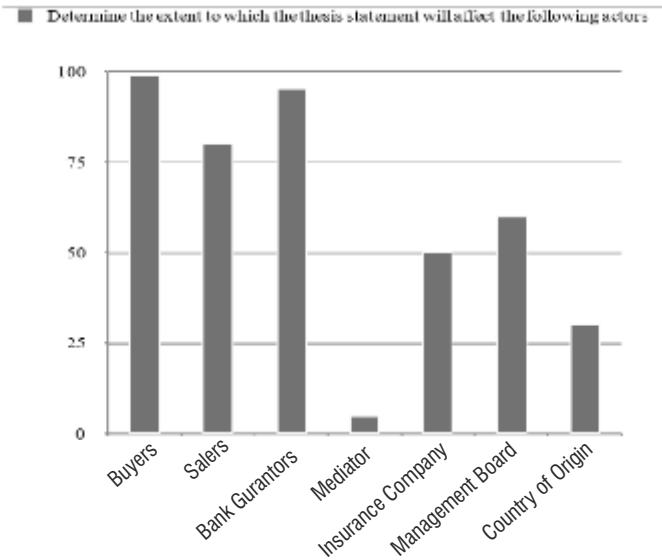

Figure 5, presents that the most effecting actors in international cases / mysterious cases are the buyers. More than 99% of the respondents gave a clear voice that it is the buyers who are most affected by the following bank guarantors (95%), salors (80%), management board (60%), insurance companies (50%), country of origin (30%), and mediator (5%). By analyzing the hypothesis and research outcomes, it has been very much applicable to the research papers. Worth mentioning that communication and an enabler's ability to negotiate in any complex environment can play a wider role in achieving certain objectives and it also reduces the risk by reducing the obstacles through effective communication skills.

Thesis 2. The buyer might had the wrong intention to order and not declare receiving the goods sent by the seller.

While testing hypothesis 2, it was found that the buyer's intentions are very clear while ordering any goods. They try to check the credibility of the seller's market image, product quality, and pricing, once satisfied, only after they place their orders. Also, the research papers establish that buyers had no wrong intention to receive the same goods and did not declare their receivings sent by the seller.

Figure 6. Respondent has selected the most effective communication tools as the ultimate tool.

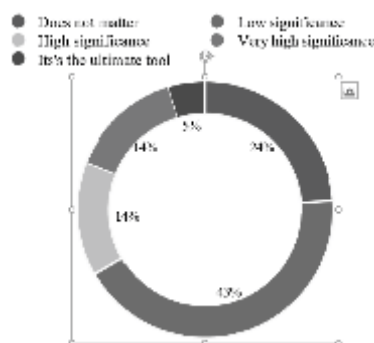
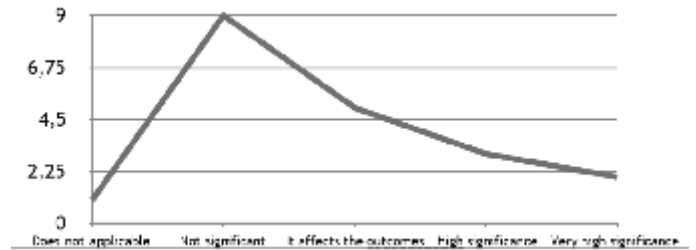

Figure 6, states that in any mishappenings oe in unwanted events communication is the only ultimate tool to solve the issues and face the challenges in such critical conditions.

Figure 7. How in your opinion, the thesis will be effective even in the Buenos Aires Case?



By analyzing the company's balance sheet invoices and transferred money confirmation sent by the buyer to the seller, it's clear that the hypothesis does not apply to the Buenos Aires Case.

Figure 8. What is the impact of the following barriers on the implementation of the thesis?

- What is the impact of the following enablers on the implementation of the thesis?

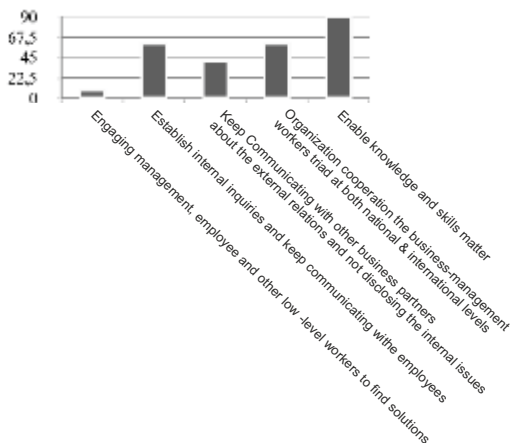

Figure 9. What is the impact of the following barriers on the implementation of the thesis?

- What is the impact of the following barriers on the implementation of the thesis?

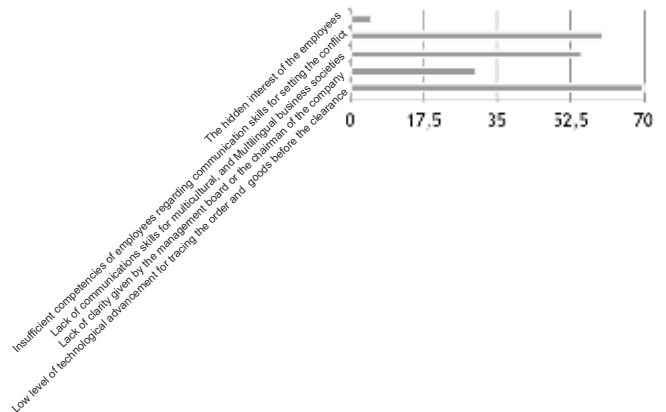
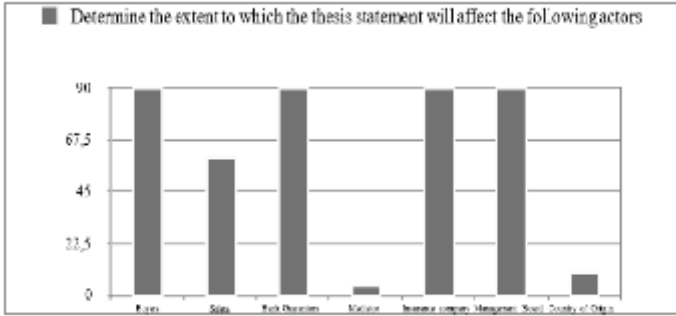

Figure 10. Determine the extent to which the thesis statement will affect the following actors, where 1 indicates that the impact of the thesis is very low, and 7 that it is very high



Thesis 3. The Sellers might had the wrong intention to get the order and not dispatch the same goods.

The research work suggests that it might be possible that sellers had the wrong intention to get the order and not dispatch the same as it was ordered. Knowing the fact that the seller's goods were covered under the letter of credit issued by the overseas buyer's bank, guarantees that they will pay them the quoted sum of money.

Figure 11. How do you assess the significance of the thesis for achieving a concrete goal as an objective, out of ongoing conflicting issues?

- Does not matter
- High significance
- Its's the ultimate tool
- Low significance
- Very high significance

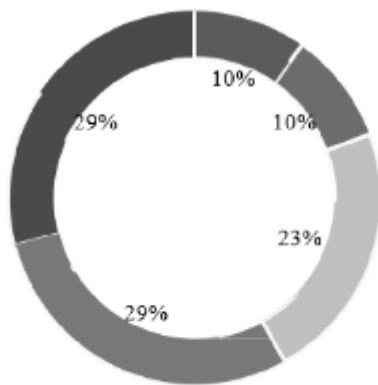

Letters of credit explained:
<https://opentoexport.com/article/letters-of-credit-explained/>

Figure 12. How in your opinion, the thesis will be effective even in the Buenos Aires Case?

◆ How in your opinion, the thesis will be effective even in the Buenos Aires Case?

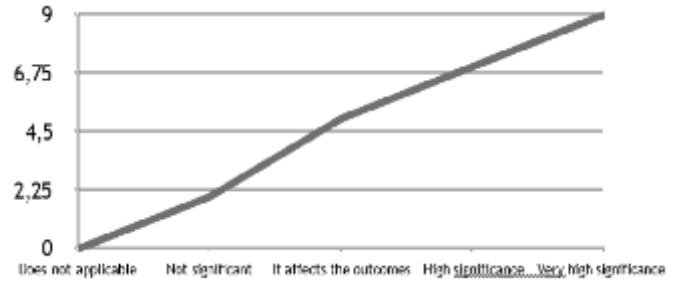
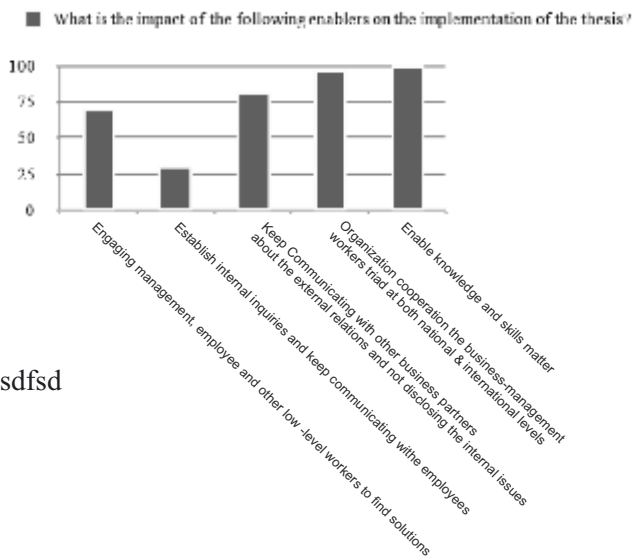

Figure 13. What is the impact of the following enablers on the implementation of the thesis?

• What is the impact of the following enablers on the implementation of the thesis?



sdfs

Figure 14. What is the impact of the following barriers on the implementation of the thesis?

• What is the impact of the following barriers on the implementation of the thesis?

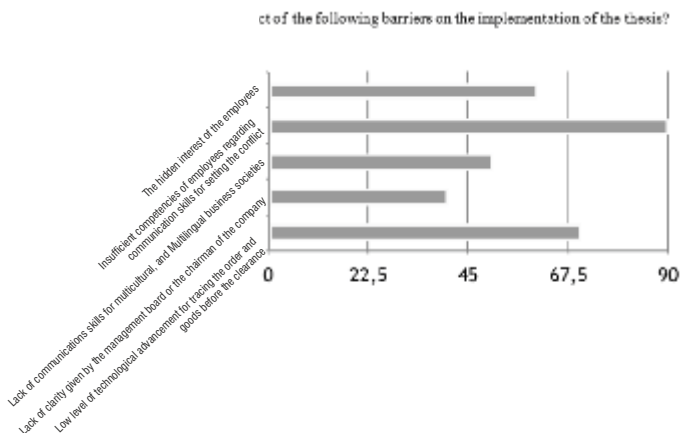
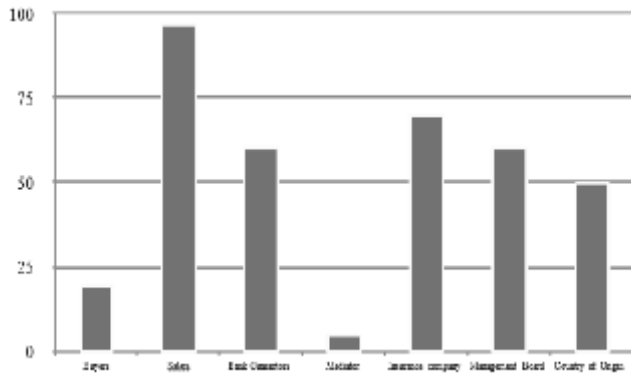

figure 15. Determine the extent to which the thesis statement will affect the following actors, where 1 indicates that the impact of the thesis is very low, and 7 that it is very high.

Determine the extent to which the thesis statement will affect the following actors.



Research figures 11, 12, 13, 14, and 15 explain why the hypothesis is applicable in this case. The ultimate beneficiary will be the seller. The buyer has already paid the ordering amount as agreed by both parties and transferred it to the seller's company. Now if anything goes wrong in all the circumstances they can claim to the back to be paid the rest of the amount either by the insurance company or Guarantor Bank.

Thesis 4. In the Buenos Aires Case, communication was the issue that dealt with the internal interest and degrading the company's image.

Figure 16. How do you assess the significance of the thesis for achieving a concrete goal as an objective, out of ongoing conflicting issues?

- Does not matter
- High significance
- Its's the ultimate tool
- Low significance
- Very high significance

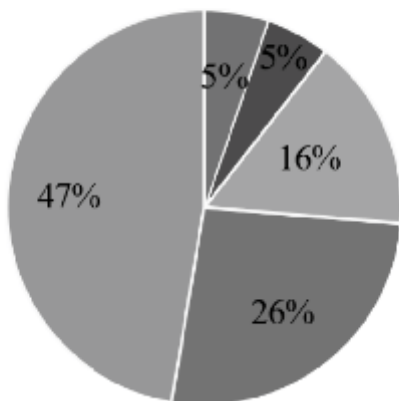

Figure 17. How in your opinion, the thesis will be effective even in the Buenos Aires Case

- How in your opinion, the thesis will be effective even in the Buenos Aires Case?

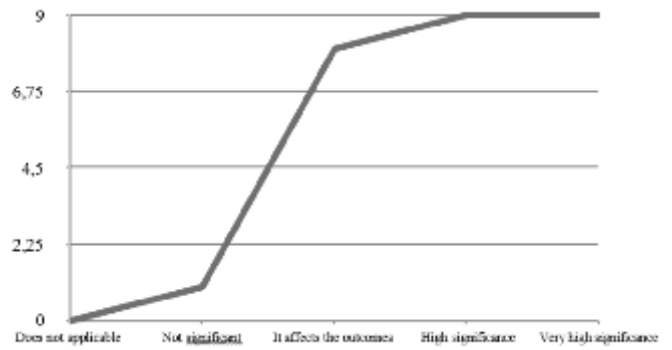

Figure 18. What is the impact of the following barriers on the implementation of the thesis?

- What is the impact of the following barriers on the implementation of the thesis?

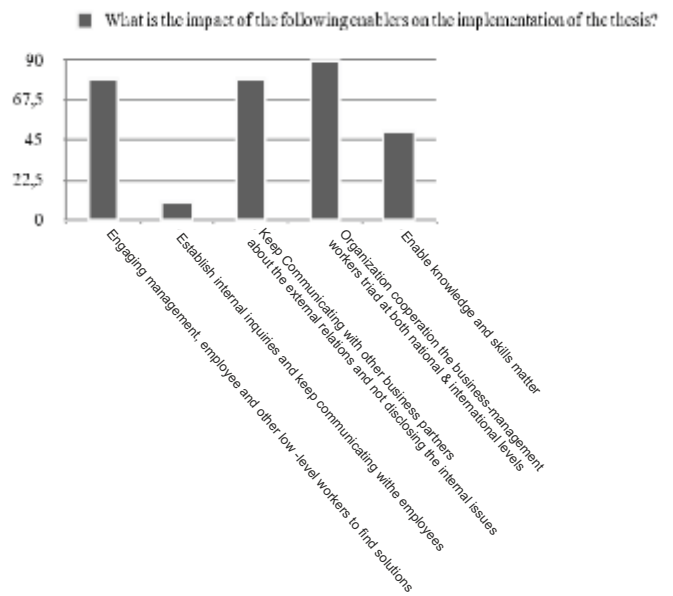
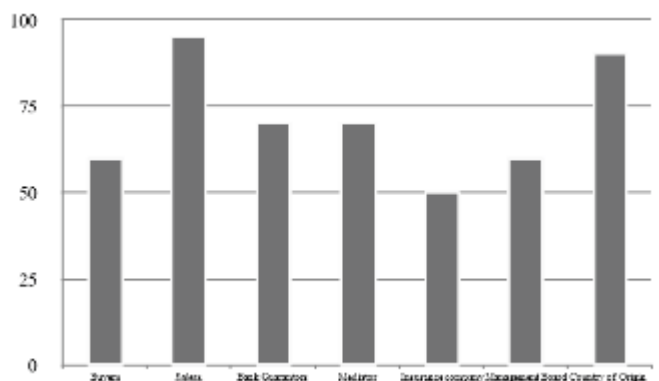

Figure 20. Determine the extent to which the thesis statement will affect the following actors, where 1 indicates that the impact of the thesis is very low, and 7 that it is very high.

- Determine the extent to which the thesis statement will affect the following actors



Thesis 5. Communication is the ultimate goal to find business solutions based on knowledge and methods applied by the mentors to create a friendly environment based on give and take/receiving and delivering methods.

Figure 21. How do you assess the significance of the thesis for achieving a concrete goal as an objective, out of ongoing conflicting issues?

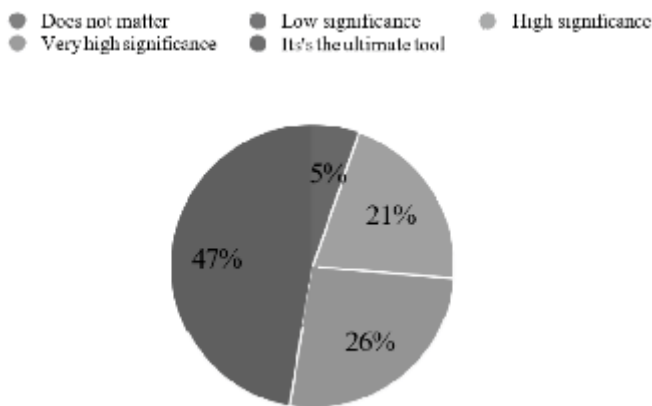

Figure 22. How in your opinion, the thesis will be effective even in the Buenos Aires Case?

How in your opinion, the thesis will be effective even in the Buenos Aires Case?

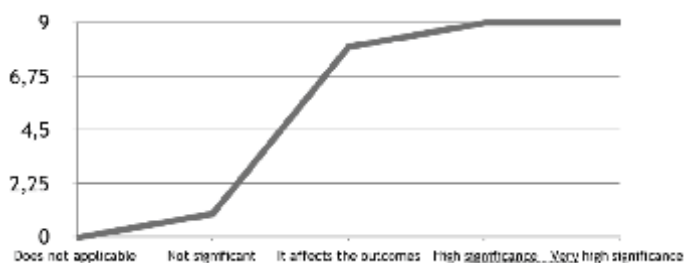

Figure 23. What is the impact of the following enablers on the implementation of the thesis?

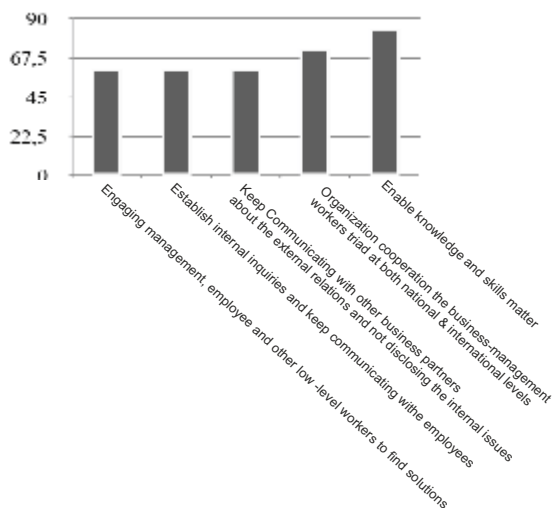

Figure 24. What is the impact of the following barriers on the implementation of the thesis?

What is the impact of the following barriers on the implementation of the thesis?

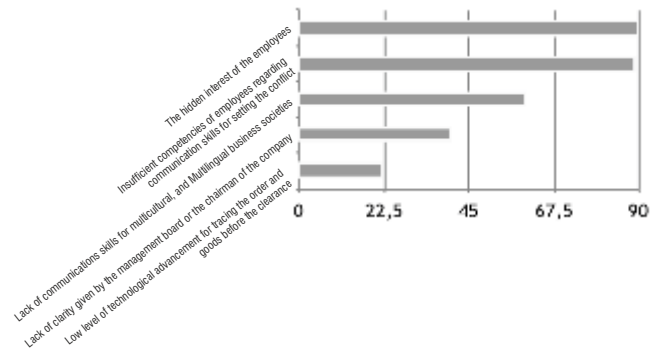
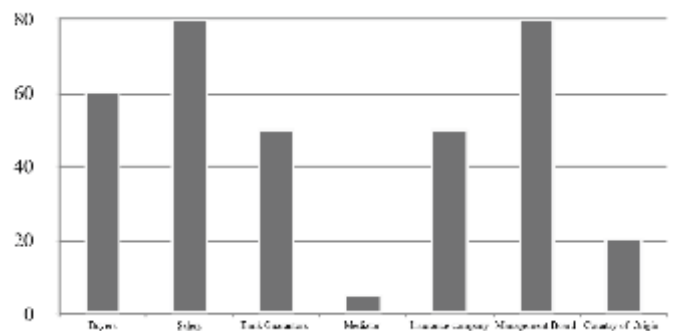

Figure 25. Determine the extent to which the thesis statement will affect the following actors, where 1 indicates that the impact of the thesis is very low, and 7 that it is very high.

Determine the extent to which the thesis statement will affect the following actors



6. Conclusion

The conflict has never benefited anyone, instead of adds one's tensions and anxiety. It is better to discuss things and reach an alternative benefiting all. It does not apply only to the business community but it is essential everywhere. The author himself has an extraordinary experience of multiculturalism and multilingualism by living in Warsaw and interacting with many young learners, research scholars, and industrial representatives daily. His experience and teaching techniques have been applied to many partner universities. At the same time practices of different languages make it more convenient to interact with many different groups and representatives. Here in this case study, it has been seen that as an enabler and supervisor of his team, the author was able to take the best from his team. The team was composed of

multinational students (e.g. Poland, India, Ukraine, Argentina, Ukraine, Morocco, and the Czech Republic) but due to their applied communication skills, they were able to deliver their best which makes them the winner of the competition.

This research is an ongoing work where communication is the ultimate tool for finding the best solutions for any complex issues occurring in our business or daily life. As it is effective for business conflict settlement it is effective to develop personal and professional relations. Especially when we believe in Vasudhaiva Kutumbakam (वसुधैव कुटुम्बकम्), which means "The World Is One Family", we should focus on finding solutions through the communication of all ongoing conflicts around us. Either it is simple communication or it's applied to mysterious cases, whether it is between individuals, corporates, or nations.

2. Reference:

- <https://pans.nysa.pl/org/ico/blog/dr-pradeep-kumar-2>
- <https://kmp.vse.cz/english/2023/11/10/international-student-business-competition-a-mysterious-business-case/>
- <https://kmp.vse.cz/english/2023/10/13/time-to-register-take-part-in-the-student-business-oriented-competition-during-our-innovation-week/>
- <https://www.linkedin.com/pulse/international-student-business-competition-mysterious-kumar-4z51c?trackingId=f5bUBYGZRdOPajOm%2BmOXUw%3D%3D/?trackingId=f5bUBYGZRdOPajOm+mOXUw==> Vasudhaiva Kutumbakam (वसुधैव कुटुम्बकम्) is a Sanskrit phrase found in Hindu texts such as the Maha Upanishad.



ABOUT IIMS:

International Institute of Management Science (IIMS) under the auspices of Yashaswi aspires to make academic issues and commitments as the key concerns for today's generation. An ISO 9001 certified, approved by AICTE and Accredited by NAAC, the Institute offers MBA, MCA Programme and Ph.D. research centre affiliated to Savitribai Phule Pune University. IIMS is a permanent Member with All India Management Association (AIMS).

The MBA (Master in Business Administration) Programme at IIMS is 2 Years full time, dual specialization programme in the areas of Marketing, Finance, Human Resource, Operations and Analytics. The course is in-sync with the latest industry happenings and practices. The students are exposed to the best training in marketing, operations, finance and management. The diverse range of studies will ensure the best career prospects for the students wherever they go.

The MCA (Master of Computer Applications) Programme is a two-year professional master's degree programme in Computer Science approved by AICTE, Government of India. The major thrust is on giving the students a sound background in computing, business functioning and mathematics relevant to information technology.

IIMS Ph.D. Research Center approved by Savitribai Phule Pune University in Commerce and Management was established in July 2021. The research area focused is Organizational Management, Marketing Management, Financial Management, Human resource Management. The major focus of the research centre is to encourage Ph.D. research candidates and faculties of institute for participating in conference, seminar, and to encourage them to take up the research projects.

The Institute also offers many value added and certification courses to inculcate required skills among the students to meet the industry standards. The young learners at the institute are encouraged to address challenges in the business world and to keep themselves abreast with key economic and business issues through structured reading, writing and research.

With a commitment to shape the global market leaders of tomorrow, IIMS aims of developing the multitalented professionals who will lead the industry and society. The Institute is located at the Central Business Activity hub of Chinchwad, Pune. It is surrounded by renowned Industries like Tata Motors, SKF Bearing, Mahale and many more. The campus is equipped with all modern teaching tools.

"Come be a part of spreading Knowledge and Skills".

ABOUT YASHASWI EDUCATION SOCIETY:

Yashaswi is a 40-year-old organization headquartered in Pune and operating more than 30 Branch offices in over 23 States. Yashaswi is one of the leading organization in India in the area of Skill Development and Vocational Education implementing its flagship program "Learn & Earn" along with other programs such as National Apprenticeship Promotion Scheme (NAPS) and National Apprenticeship Training Scheme (NATS) in more than 900+ organizations with a current strength of 80,000 Trainees.

Yashaswi, through its Skill Development Centers across India, provides skill education to Health Care, Engineering, BFSI, etc. also engaged in imparting management education and being affiliated with Savitribai Phule Pune University for the programs like MBA & MCA. Yashaswi is engaged in implementing CSR projects in the area of women empowerment, employability enhancement and entrepreneurship development for the industries like Tata Motors Ltd, GKN Sinter Metal Pvt Ltd, Tata Power, Persistent System, Kotak Mahindra Foundation, Cummins Technologies India Pvt Ltd, Dr. Reddy's, Tata Sky, Lupin Ltd, Cipla Ltd, Micro Lab Ltd, etc. Yashaswi is also engaged in the area of Temp Staffing and Permanent Recruitment.



PUBLISHER DETAILS:

DR. SHIVAJI MUNDHE - Editor-in-chief

Yashaswi Bhavan, Opp. Elpro International, Near Ramkrishna More Auditorium, Chinchwad, Pune-411033.

Mobile : +91 98222423222 | **E-mail :** editor@yashomanthan.co.in, iims.director@yashswigroup.in

PUBLISHER ADDRESS :

Yashaswi Education Society's

INTERNATIONAL INSTITUTE OF MANAGEMENT SCIENCE

Yashaswi Bhavan, Opp. Elpro International, Near Ramkrishna More Auditorium, Chinchwad, Pune-411033.

Mobile : +91 9850680418 | **E-mail:** iims.research@yashswigroup.in



Yashaswi Education Society's

INTERNATIONAL INSTITUTE OF MANAGEMENT SCIENCE

An ISO 9001 Certified Institute

(Approved by AICTE Ministry of HRD Govt. of India, Recognized by DTE Govt. of Maharashtra & Affiliated to Savitribai Phule Pune University, NAAC Accredited)



Corporate Office : Yashaswi House, CTS No. 72/1, Plot No. 105/1A, Prabhat Road, Lane No. 15, Erandwane, Pune - 411 004,

IIMS Campus : Yashaswi Bhavan, Opp. Elpro International, Near Ramkrishna More Auditorium, Chinchwad, Pune-411033.

L.: (020) 27353727/28/29/30 • **M.:** +91 7350014526 • **E.:** info@iims.ac.in • **W.:** www.iims.ac.in